

**etts®**

**Excellence is our Signature  
and Quality is our  
Commitment**



**DESIGN  
COLLECTION  
2025**

**EXCLUSIVE DOORS &  
WINDOWS HARDWARE  
ACCESSORIES**

## Company Profile

### Overview :

Atul Brass Works has been working in the doors and windows hardware industry since its establishment in 1963, with over six decades of expertise, the company has built a reputation for delivering high-quality, durable, and aesthetically pleasing hardware solutions under its renowned brand, **etts**®.

### Products and Services :

The company specializes in designing and importing a comprehensive range of hardware products for doors and windows.

### Key Strengths :

**Quality Craftsmanship** : Each product is crafted with precision using high-grade materials, ensuring superior durability and performance.

**Innovative Designs** : **etts**® is known for its modern yet timeless designs, catering to diverse architectural styles and customer preferences.

**Customer Trust** : Atul Brass Works has cultivated long-standing relationships with clients, becoming a trusted partner for homeowners, architects, and builders.

### Legacy and Vision :

Atul Brass Works has remained committed to excellence since its inception. The company continuously strives to innovate and expand its product portfolio, ensuring it stays ahead in the competitive market. With a deep-rooted legacy and a forward-looking approach, Atul Brass Works aims to uphold its position as a leader in the hardware industry while catering to evolving customer needs.



• Sliding Window Multi Point Handles

04-08

09-15

• Sliding Window Conceal Locks  
• Window Rollers

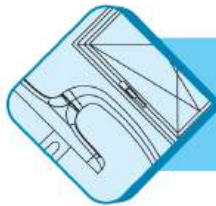
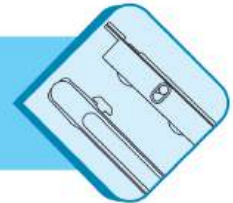

• Tilt & Turn Accessories  
• Casement Window Multi Point Handles

16-20

21-26

• Casement Window Single Point Handles  
• Window Hinges

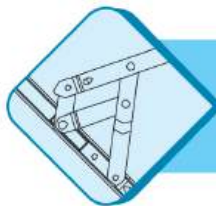
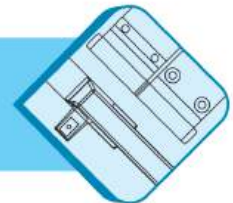

• Friction Stay  
• Arm Stay

27-32

33-36

• Mortise Handles  
• Lock Body

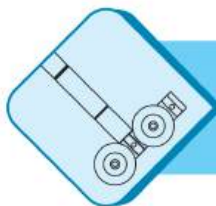

• Sliding Folding Accessories

37-38

41-46

• Sliding Window Handles  
• Casement Window Handles

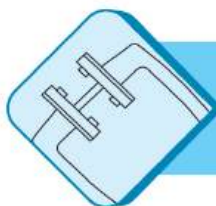
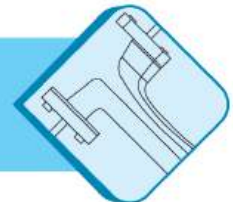

• Door Handles  
• Espag Rods

47-52

53-58

• uPVC Hinges  
• uPVC Window Rollers





# SLIDING MULTI POINT HANDLE

**AMP-55**

**Description : Aluminium Multi Point Lock Handle**

| Code     | Finish               |
|----------|----------------------|
| AMP-55-B | Black Sand Blasting  |
| AMP-55-S | Silver Sand Blasting |

**Description : Aluminium Multi Point Lock Handle (Rear)**

| Code      | Finish               |
|-----------|----------------------|
| AMP-55-BD | Black Sand Blasting  |
| AMP-55-SD | Silver Sand Blasting |

**Description : Aluminium Locking Strip**

| Code        | Code       | Code       |
|-------------|------------|------------|
| AMP-LS-1200 | MP-14-800  | MP-14-1400 |
| MP-14-400   | MP-14-1000 | MP-14-1600 |
| MP-14-600   | MP-14-1200 | MP-14-1800 |

Product Drawing

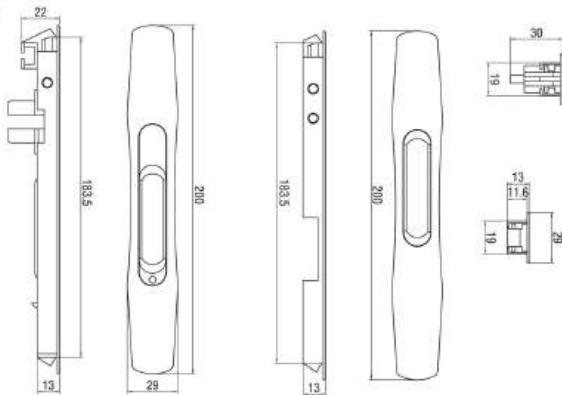

# SLIDING MULTI POINT HANDLE

**AMP-55-K**

**Description : Aluminium Multi Point Lock Handle (Key)**

| Code      | Finish               |
|-----------|----------------------|
| AMP-55-KB | Black Sand Blasting  |
| AMP-55-KS | Silver Sand Blasting |

**Description : Aluminium Multi Point Lock Handle (Rear)**

| Code      | Finish               |
|-----------|----------------------|
| AMP-55-BD | Black Sand Blasting  |
| AMP-55-SD | Silver Sand Blasting |

**Description : Aluminium Locking Strip**

| Code        | Code       | Code       |
|-------------|------------|------------|
| AMP-LS-1200 | MP-14-800  | MP-14-1400 |
| MP-14-400   | MP-14-1000 | MP-14-1600 |
| MP-14-600   | MP-14-1200 | MP-14-1800 |

Product Drawing

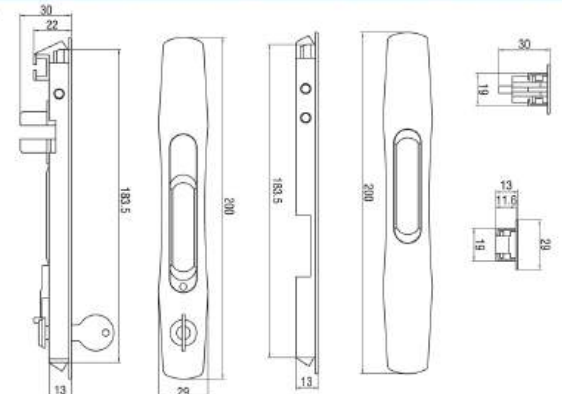

# AMP-110-270 SLIDING MULTI POINT HANDLE



**Description : Aluminium Multi Point Lock Handle**

| Code          | Finish               |
|---------------|----------------------|
| AMP-110-B-270 | Black Powder Coating |
| AMP-110-W-270 | White Powder Coating |

**Description : Aluminium Multi Point Lock Handle (Rear)**

| Code           | Finish               |
|----------------|----------------------|
| AMP-110-BD-270 | Black Powder Coating |
| AMP-110-WD-270 | White Powder Coating |

**Description : Aluminium Locking Strip**

| Code        | Code       | Code       |
|-------------|------------|------------|
| AMP-LS-1200 | MP-14-800  | MP-14-1400 |
| MP-14-400   | MP-14-1000 | MP-14-1600 |
| MP-14-600   | MP-14-1200 | MP-14-1800 |

Product Drawing

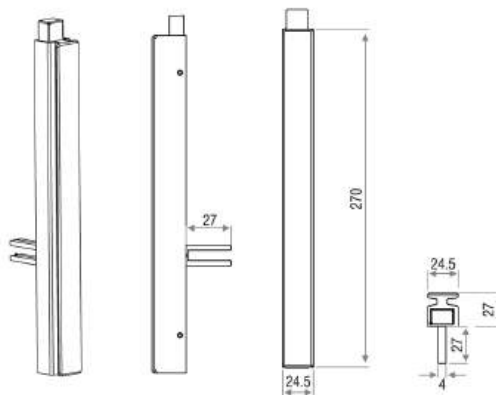

# AMP-110-K-270 SLIDING MULTI POINT HANDLE



**Description : Aluminium Multi Point Lock Handle (Key)**

| Code           | Finish               |
|----------------|----------------------|
| AMP-110-KB-270 | Black Powder Coating |
| AMP-110-KW-270 | White Powder Coating |

**Description : Aluminium Locking Strip**

| Code        | Code       | Code       |
|-------------|------------|------------|
| AMP-LS-1200 | MP-14-800  | MP-14-1400 |
| MP-14-400   | MP-14-1000 | MP-14-1600 |
| MP-14-600   | MP-14-1200 | MP-14-1800 |

Product Drawing

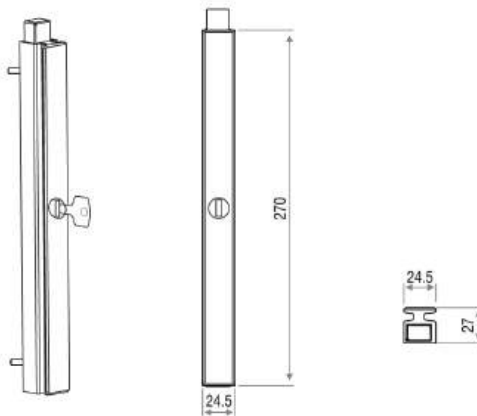

# SLIDING MULTI POINT HANDLE AMP-110-150

**Description : Aluminium Multi Point Lock Handle**

| Code          | Finish               |
|---------------|----------------------|
| AMP-110-B-150 | Black Powder Coating |
| AMP-110-W-150 | White Powder Coating |

**Description : Aluminium Locking Strip**

| Code        | Code       | Code       |
|-------------|------------|------------|
| AMP-LS-1200 | MP-14-800  | MP-14-1400 |
| MP-14-400   | MP-14-1000 | MP-14-1600 |
| MP-14-600   | MP-14-1200 | MP-14-1800 |

Product Drawing

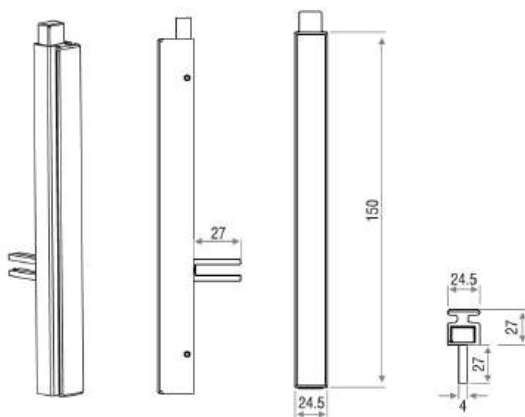

# SLIDING MULTI POINT HANDLE MP-60

**Description : Aluminium Multi Point Lock Handle**

| Code    | Finish               |
|---------|----------------------|
| MP-60-B | Black Powder Coating |
| MP-60-W | White Powder Coating |

**Description : Aluminium Locking Strip**

| Code      | Code       | Code       |
|-----------|------------|------------|
| MP-14-400 | MP-14-1000 | MP-14-1600 |
| MP-14-600 | MP-14-1200 | MP-14-1800 |
| MP-14-800 | MP-14-1400 |            |

Product Drawing

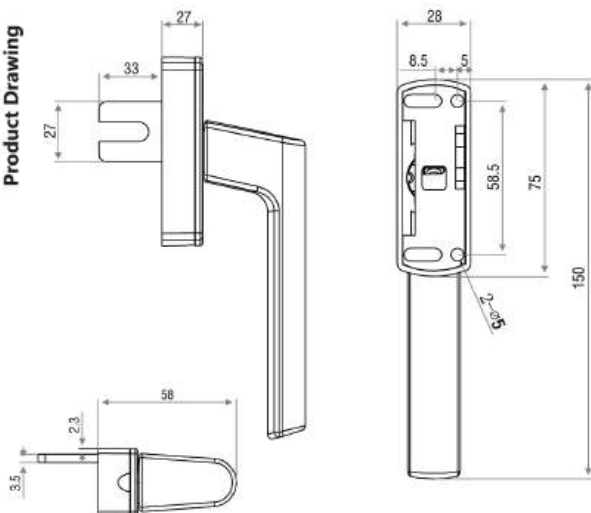

## MP-72

# SLIDING MULTI POINT HANDLE



### Description : Aluminium Multi Point Lock Handle

| Code    | Finish               |
|---------|----------------------|
| MP-72-B | Black Powder Coating |
| MP-72-W | White Powder Coating |

### Description : Transmission Rod

| Code       | Size   | Back Set |
|------------|--------|----------|
| TR-75-1000 | 1000mm | 7.5mm    |
| TR-75-1600 | 1600mm | 7.5mm    |
| TR-75-1800 | 1800mm | 7.5mm    |

Product Drawing

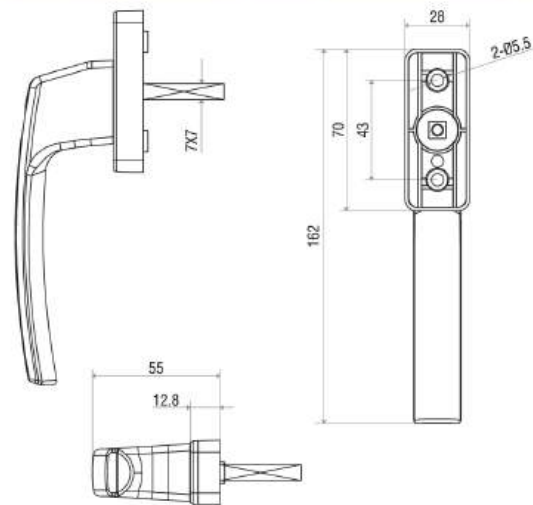

## MP-72-K

# SLIDING MULTI POINT HANDLE



### Description : Aluminium Multi Point Lock Handle (Key)

| Code     | Finish               |
|----------|----------------------|
| MP-72-KB | Black Powder Coating |
| MP-72-KW | White Powder Coating |

### Description : Transmission Rod

| Code       | Size   | Back Set |
|------------|--------|----------|
| TR-75-1000 | 1000mm | 7.5mm    |
| TR-75-1600 | 1600mm | 7.5mm    |
| TR-75-1800 | 1800mm | 7.5mm    |

Product Drawing

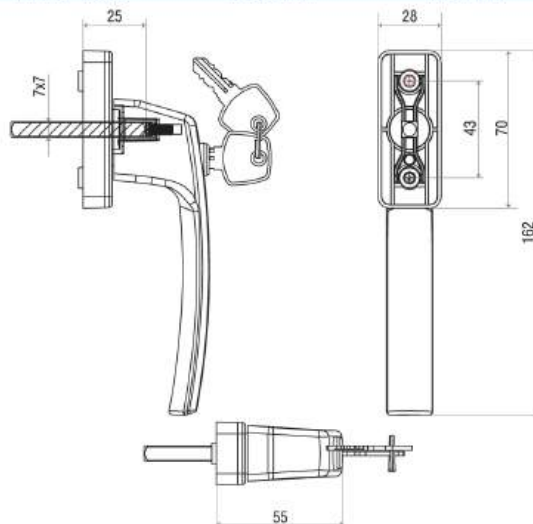



# SLIDING MULTI POINT HANDLE (SHORT NECK)

**MP-75**

**Description : Aluminium Multi Point Lock Handle**

| Code    | Finish               |
|---------|----------------------|
| MP-75-B | Black Powder Coating |
| MP-75-W | White Powder Coating |

**Description : Transmission Rod**

| Code       | Size   | Back Set |
|------------|--------|----------|
| TR-75-1000 | 1000mm | 7.5mm    |
| TR-75-1600 | 1600mm | 7.5mm    |
| TR-75-1800 | 1800mm | 7.5mm    |

Product Drawing

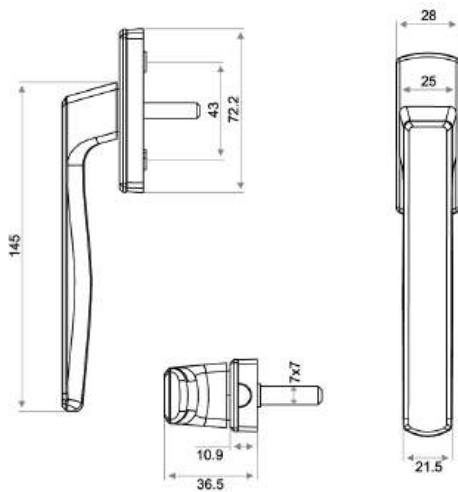

# SLIDING MULTI POINT HANDLE

**MP-81**

**Description : Aluminium Multi Point Lock Handle**

| Code    | Finish               |
|---------|----------------------|
| MP-81-B | Black Powder Coating |
| MP-81-W | White Powder Coating |

**Description : Transmission Rod**

| Code       | Size   | Back Set |
|------------|--------|----------|
| TR-75-1000 | 1000mm | 7.5mm    |
| TR-75-1600 | 1600mm | 7.5mm    |
| TR-75-1800 | 1800mm | 7.5mm    |

Product Drawing

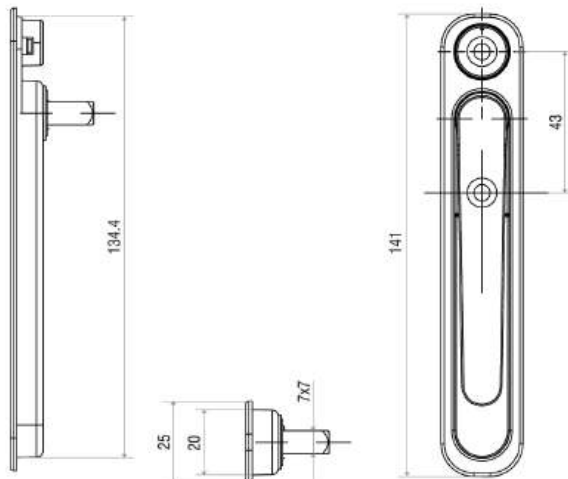

**ACL-45**

**CONCEAL LOCK**



**Description : Aluminium Conceal Lock**

| Code     | Finish               | System    |
|----------|----------------------|-----------|
| ACL-45-B | Black Sand Blasting  | Automatic |
| ACL-45-S | Silver Sand Blasting | Automatic |
| ACL-45-G | Golden Sand Blasting | Automatic |

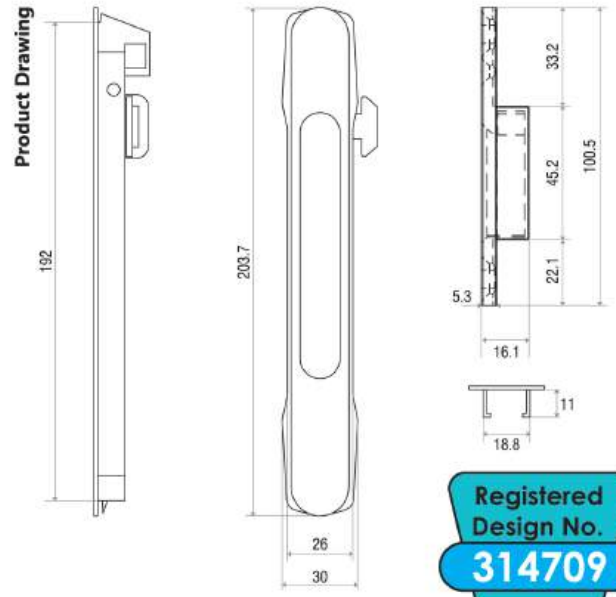

**ACL-35**

**CONCEAL LOCK**



**Description : Aluminium Conceal Lock**

| Code     | Finish                | System    |
|----------|-----------------------|-----------|
| ACL-35-B | Black Powder Coating  | Automatic |
| ACL-35-W | White Powder Coating  | Automatic |
| ACL-35-G | Golden Powder Coating | Automatic |

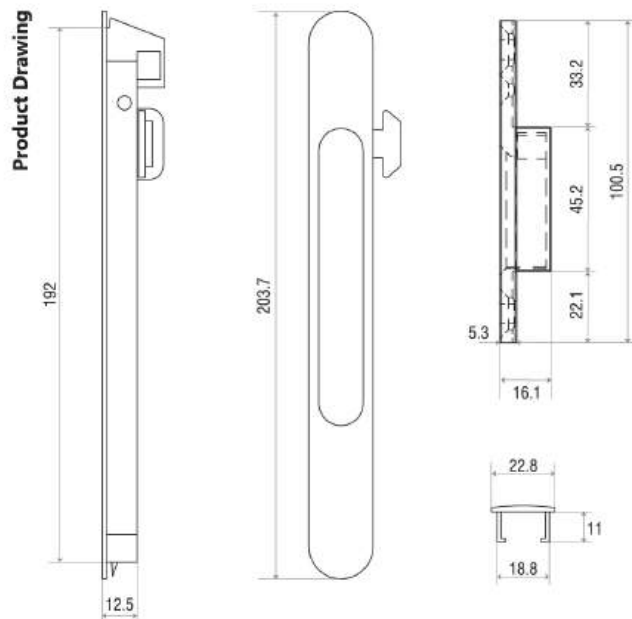

# CONCEAL LOCK (MANUAL)

**ACL-34-MN**

**Description : Aluminium Conceal Lock**

| Code        | Finish                | System |
|-------------|-----------------------|--------|
| ACL-34-MN-B | Black Powder Coating  | Manual |
| ACL-34-MN-W | White Powder Coating  | Manual |
| ACL-34-MN-G | Golden Powder Coating | Manual |

Product Drawing

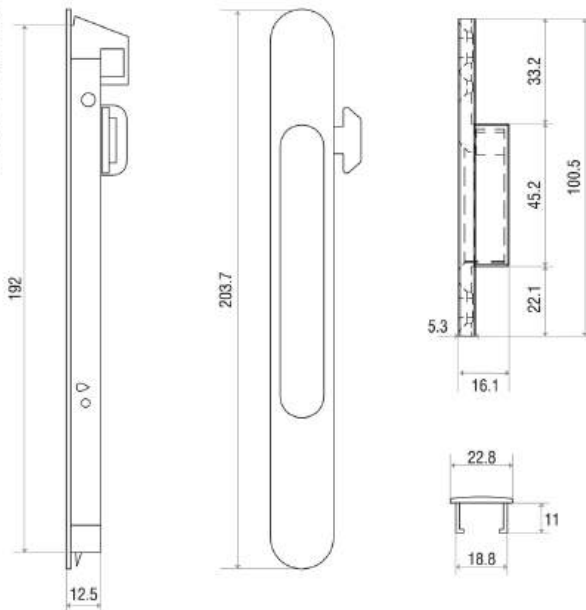

ACL-34-MN-B



# CONCEAL LOCK

**ACL-30**

**Description : Aluminium Conceal Lock**

| Code     | Finish               | System    |
|----------|----------------------|-----------|
| ACL-30-B | Black Powder Coating | Automatic |
| ACL-30-W | White Powder Coating | Automatic |

Product Drawing

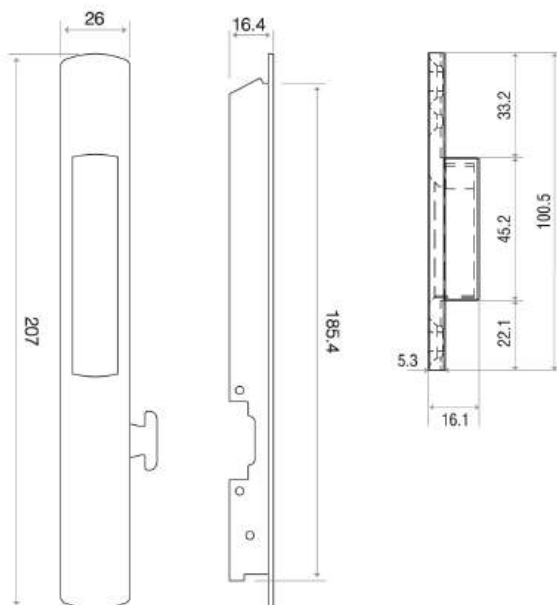

ACL-30-B



**ACL-25**

**CONCEAL LOCK**



ACL-25-B

ACL-25-DB

**Description : Aluminium Conceal Lock**

| Code     | Finish               | System           |
|----------|----------------------|------------------|
| ACL-25-B | Black Powder Coating | Automatic/Manual |
| ACL-25-W | White Powder Coating | Automatic/Manual |

**Description : Aluminium Conceal Lock (Rear)**

| Code      | Finish               |
|-----------|----------------------|
| ACL-25-DB | Black Powder Coating |
| ACL-25-DW | White Powder Coating |

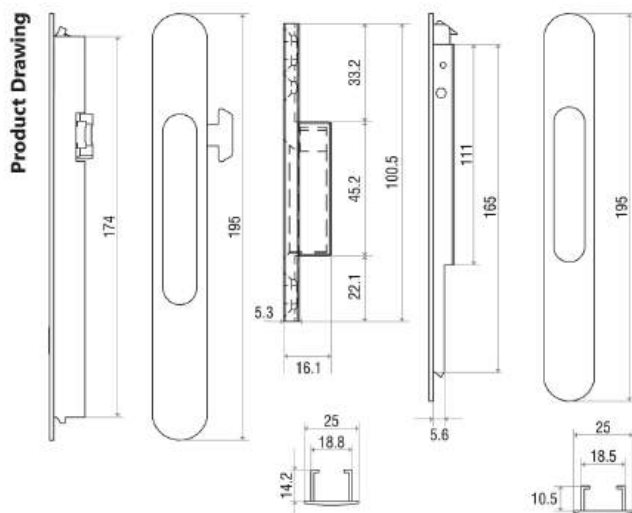

**ACL-25-P**

**CONCEAL LOCK**



ACL-25-PB

ACL-25-DB

**Description : Aluminium Conceal Lock (Push Button)**

| Code      | Finish               |
|-----------|----------------------|
| ACL-25-PB | Black Powder Coating |
| ACL-25-PW | White Powder Coating |

**Description : Aluminium Conceal Lock (Rear)**

| Code      | Finish               |
|-----------|----------------------|
| ACL-25-DB | Black Powder Coating |
| ACL-25-DW | White Powder Coating |

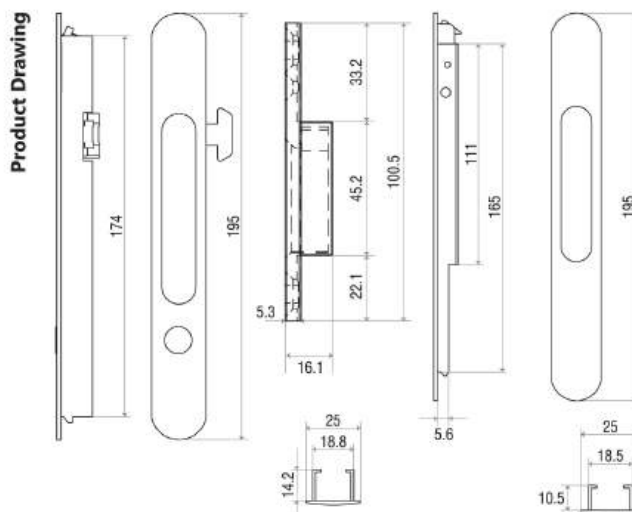

# CONCEAL LOCK ACL-25-K

**Description : Aluminium Conceal Lock (Key)**

| Code      | Finish               |
|-----------|----------------------|
| ACL-25-KB | Black Powder Coating |
| ACL-25-KW | White Powder Coating |

**Description : Aluminium Conceal Lock (Rear)**

| Code      | Finish               |
|-----------|----------------------|
| ACL-25-DB | Black Powder Coating |
| ACL-25-DW | White Powder Coating |

Product Drawing

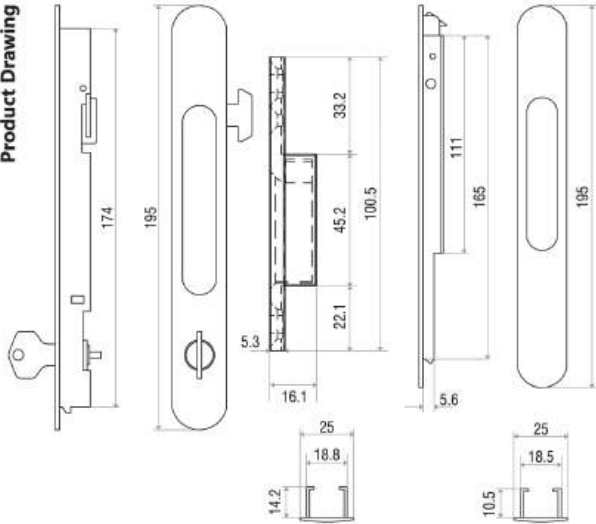

ACL-25-KB



ACL-25-DB



# CONCEAL LOCK ACL-20

**Description : Aluminium Conceal Lock**

| Code     | Finish               |
|----------|----------------------|
| ACL-20-B | Black Powder Coating |
| ACL-20-W | White Powder Coating |

Product Drawing

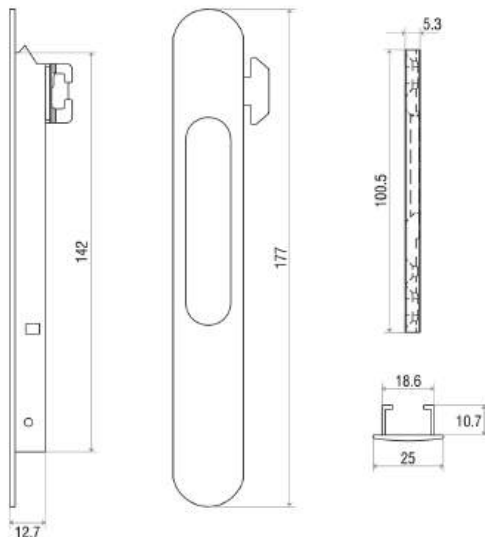

ACL-20-B



# AWR-28

# WINDOW ROLLER

**AWR-28-V**  
"V" Groove



**AWR-28-R**  
Round Groove



Registered  
Design No.  
**314708**

**Description : Window Roller**

| Code     | Weight Capacity | Groove | Type       |
|----------|-----------------|--------|------------|
| AWR-28-V | 110 kgs.        | "V"    | Adjustable |
| AWR-28-R | 110 kgs.        | "R"    | Adjustable |



Product Drawing

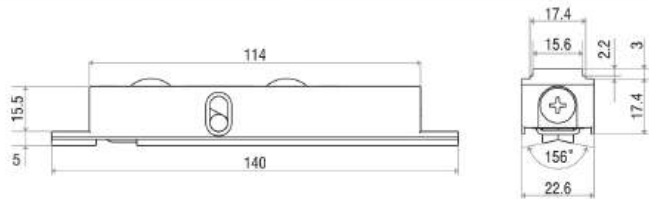

# AWR-35

# WINDOW ROLLER

**AWR-35-V**  
"V" Groove



**AWR-35-R**  
Round Groove



Registered  
Design No.  
**314708**

**Description : Window Roller**

| Code     | Weight Capacity | Groove | Type       |
|----------|-----------------|--------|------------|
| AWR-35-V | 110 kgs.        | "V"    | Adjustable |
| AWR-35-R | 110 kgs.        | "R"    | Adjustable |



Product Drawing

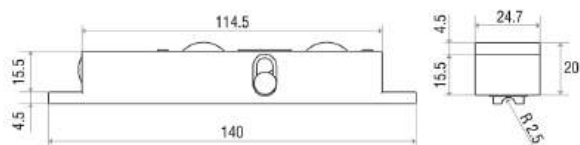

# SS WINDOW ROLLER AWR-1517

**AWR-1517-150**  
2 - Wheel



**AWR-1517-240**  
4 - Wheel



**Description : Window Roller**

| Code         | Weight Capacity | Finish | Type       |
|--------------|-----------------|--------|------------|
| AWR-1517-150 | 80 kgs.         | SS     | Adjustable |
| AWR-1517-240 | 130 kgs.        | SS     | Adjustable |

Product Drawing

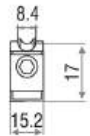
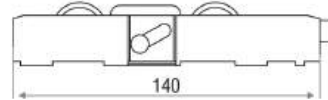
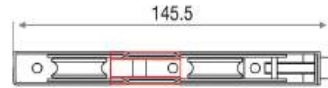
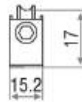
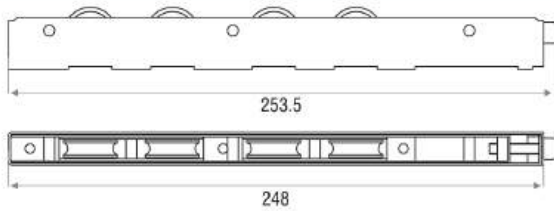

# SS WINDOW ROLLER AWR-1524

**AWR-1524-150**  
2 - Wheel



**AWR-1524-240**  
4 - Wheel



**Description : Window Roller**

| Code         | Weight Capacity | Finish | Type       |
|--------------|-----------------|--------|------------|
| AWR-1524-150 | 80 kgs.         | SS     | Adjustable |
| AWR-1524-240 | 130 kgs.        | SS     | Adjustable |

Product Drawing

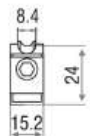
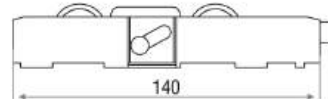
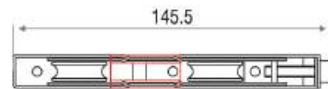
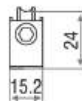
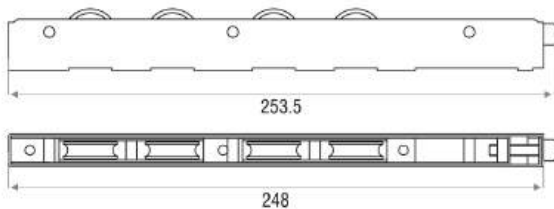

# AWR-FIX-28 WINDOW ROLLER

**AWR-FIX-28-V**  
"V" Groove



**AWR-FIX-28-R**  
Round Groove

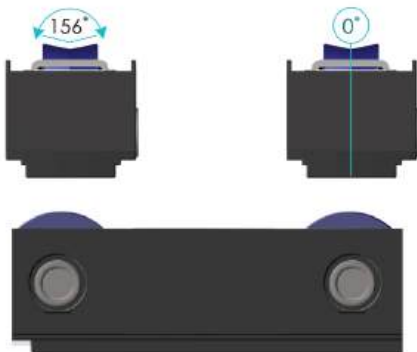

Machine Riveting

**Description : Window Roller**

| Code         | Weight Capacity | Groove | Type |
|--------------|-----------------|--------|------|
| AWR-FIX-28-V | 60 kgs.         | "V"    | Fix  |
| AWR-FIX-28-R | 60 kgs.         | "R"    | Fix  |

Product Drawing

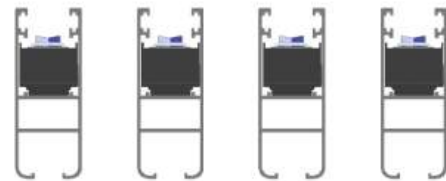
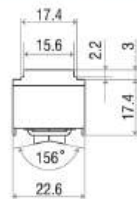

# MP & TR ALUMINIUM LOCKING STRIP

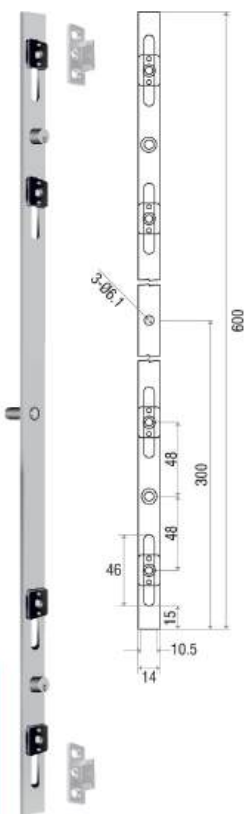

MP-01

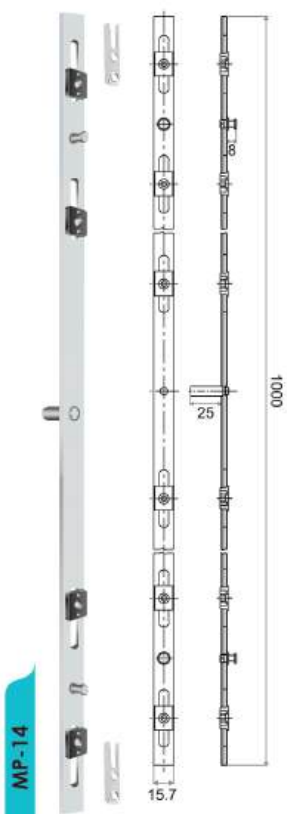

MP-14

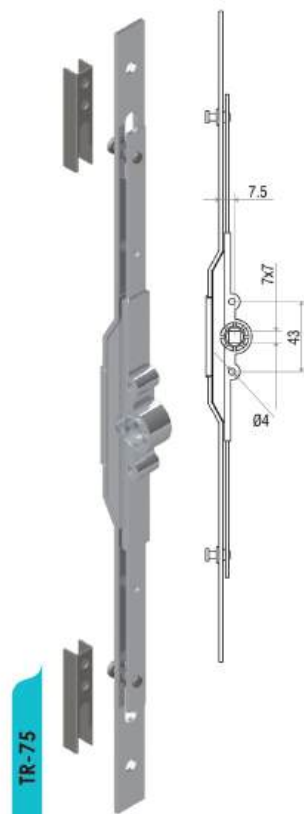

TR-75

**Description : Aluminium Locking Strip**

| Code       | Type     | Length |
|------------|----------|--------|
| MP-01-400  | Casement | 400mm  |
| MP-01-600  | Casement | 600mm  |
| MP-01-800  | Casement | 800mm  |
| MP-01-1000 | Casement | 1000mm |
| MP-01-1200 | Casement | 1200mm |
| MP-01-1400 | Casement | 1400mm |
| MP-01-1600 | Casement | 1600mm |
| MP-01-1800 | Casement | 1800mm |

**Description : Aluminium Locking Strip**

| Code       | Type    | Length |
|------------|---------|--------|
| MP-14-400  | Sliding | 400mm  |
| MP-14-600  | Sliding | 600mm  |
| MP-14-800  | Sliding | 800mm  |
| MP-14-1000 | Sliding | 1000mm |
| MP-14-1200 | Sliding | 1200mm |
| MP-14-1400 | Sliding | 1400mm |
| MP-14-1600 | Sliding | 1600mm |
| MP-14-1800 | Sliding | 1800mm |

**Description : Transmission Rod**

| Code       | Back Set | Length |
|------------|----------|--------|
| TR-75-1000 | 7.5mm    | 1000mm |
| TR-75-1600 | 7.5mm    | 1600mm |
| TR-75-1800 | 7.5mm    | 1800mm |



## TILT &amp; TURN WINDOW ACCESSORIES

TT-EU

(EURO GROOVE)

Product Drawing

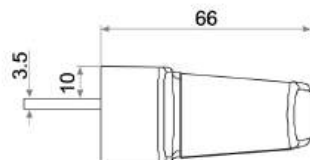
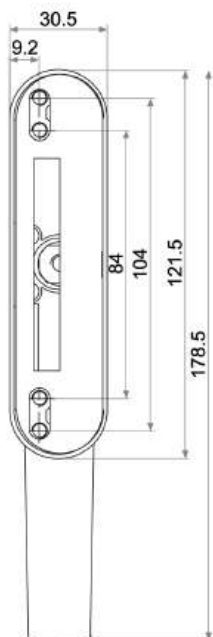
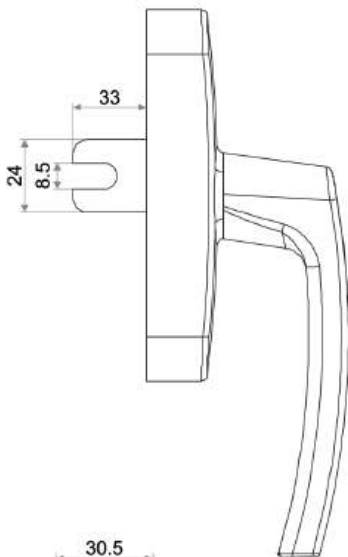
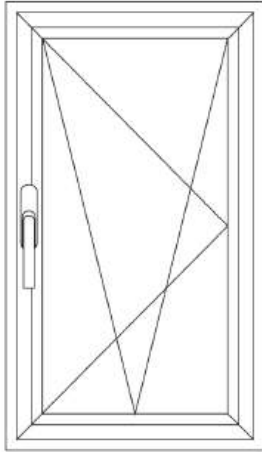

## Description : Tilt &amp; Turn Window Accessories

| Code     | Finish | L & R |
|----------|--------|-------|
| TT-EU-BR | Black  | Right |
| TT-EU-BL | Black  | Left  |

## Description : Only Handle

| Code       | Finish |
|------------|--------|
| TT-EU-HN-W | White  |

# MP-54-PRM CASEMENT MULTI POINT HANDLE



**Description : Aluminium Multi Point Lock Handle**

| Code        | Finish               |
|-------------|----------------------|
| MP-54-PRM-B | Black Powder Coating |
| MP-54-PRM-W | White Powder Coating |

**Description : Aluminium Locking Strip**

| Code      | Code       | Code       | Code       |
|-----------|------------|------------|------------|
| MP-01-400 | MP-01-800  | MP-01-1200 | MP-01-1600 |
| MP-01-600 | MP-01-1000 | MP-01-1400 | MP-01-1800 |

Product Drawing

PREMIUM

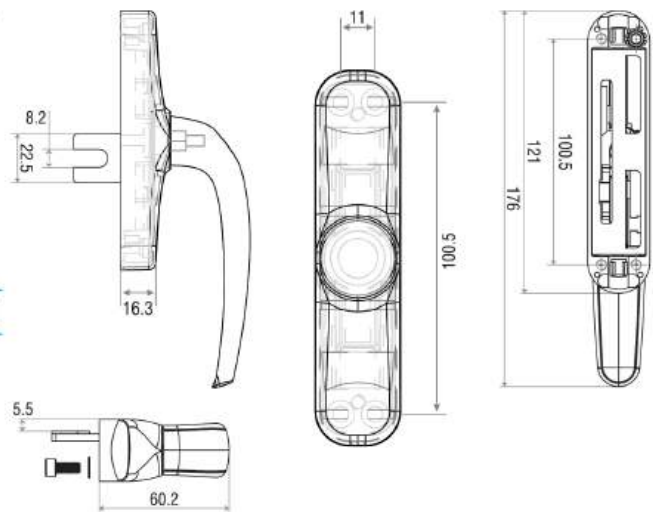

# MP-54 CASEMENT MULTI POINT HANDLE



**Description : Aluminium Multi Point Lock Handle**

| Code                   | Finish               |
|------------------------|----------------------|
| MP-54-B                | Black Powder Coating |
| MP-54-W                | White Powder Coating |
| MP-54-B-50 (Fork 50mm) | Black Powder Coating |
| MP-54-W-50 (Fork 50mm) | White Powder Coating |

**Description : Aluminium Locking Strip**

| Code      | Code       | Code       | Code       |
|-----------|------------|------------|------------|
| MP-01-400 | MP-01-800  | MP-01-1200 | MP-01-1600 |
| MP-01-600 | MP-01-1000 | MP-01-1400 | MP-01-1800 |

Product Drawing

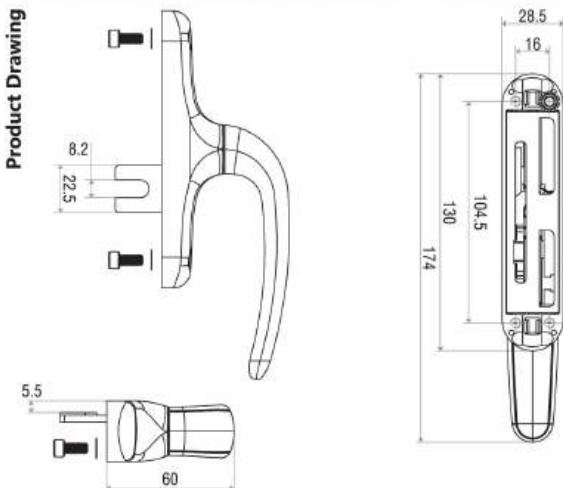

# CASEMENT MULTI POINT HANDLE

**MP-54-K**

**Description : Aluminium Multi Point Lock Handle (Key)**

| Code     | Finish               |
|----------|----------------------|
| MP-54-KB | Black Powder Coating |
| MP-54-KW | White Powder Coating |

**Description : Aluminium Locking Strip**

| Code      | Code       | Code       | Code       |
|-----------|------------|------------|------------|
| MP-01-400 | MP-01-800  | MP-01-1200 | MP-01-1600 |
| MP-01-600 | MP-01-1000 | MP-01-1400 | MP-01-1800 |

Product Drawing

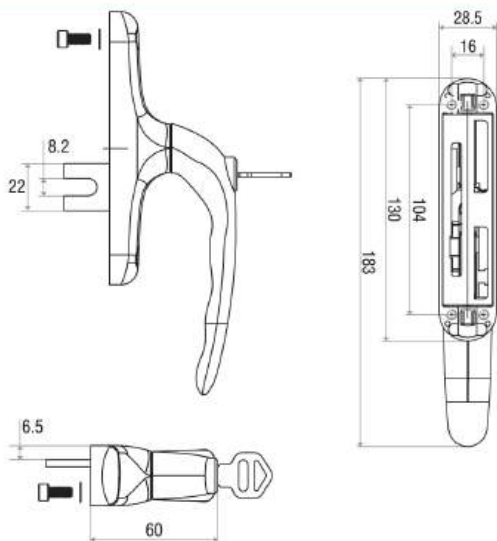

# CASEMENT MULTI POINT HANDLE

**MP-56**

**Description : Aluminium Multi Point Lock Handle**

| Code        | Finish               |
|-------------|----------------------|
| MP-56-B     | Black Powder Coating |
| MP-56-W     | White Powder Coating |
| MP-LK-ACC-1 | SN (Accessories)     |

Product Drawing

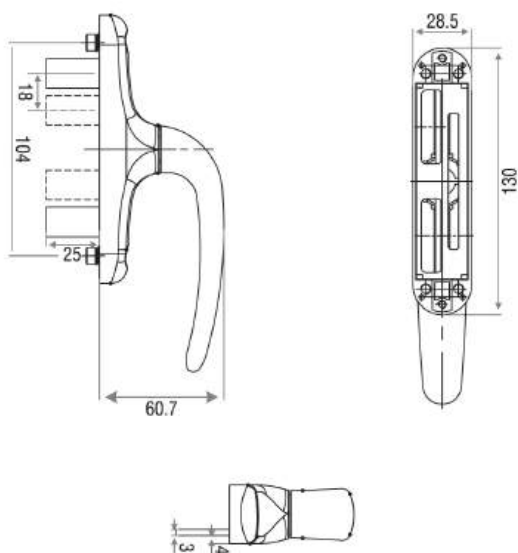

**MP-65**

**CASEMENT MULTI POINT HANDLE**



**Description : Aluminium Multi Point Lock Handle**

| Code    | Finish               |
|---------|----------------------|
| MP-65-B | Black Powder Coating |
| MP-65-W | White Powder Coating |

**Description : Aluminium Locking Strip**

| Code      | Code       | Code       | Code       |
|-----------|------------|------------|------------|
| MP-01-400 | MP-01-800  | MP-01-1200 | MP-01-1600 |
| MP-01-600 | MP-01-1000 | MP-01-1400 | MP-01-1800 |

Product Drawing

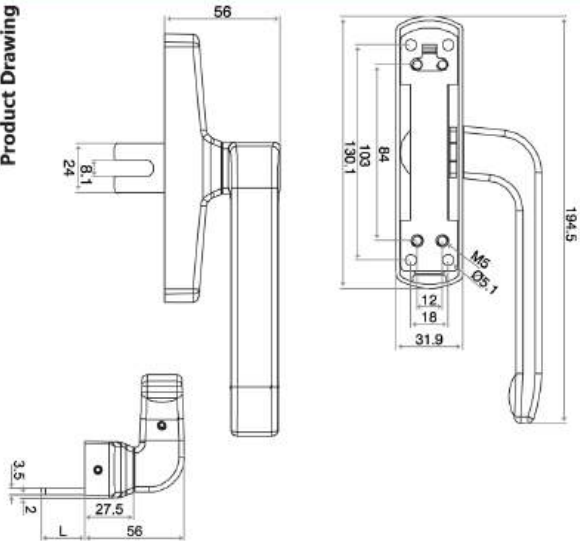

**MP-63**

**CASEMENT MULTI POINT HANDLE**



**Description : Aluminium Multi Point Lock Handle**

| Code    | Finish               |
|---------|----------------------|
| MP-63-B | Black Powder Coating |
| MP-63-W | White Powder Coating |

**Description : Aluminium Locking Strip**

| Code      | Code       | Code       | Code       |
|-----------|------------|------------|------------|
| MP-01-400 | MP-01-800  | MP-01-1200 | MP-01-1600 |
| MP-01-600 | MP-01-1000 | MP-01-1400 | MP-01-1800 |

Product Drawing

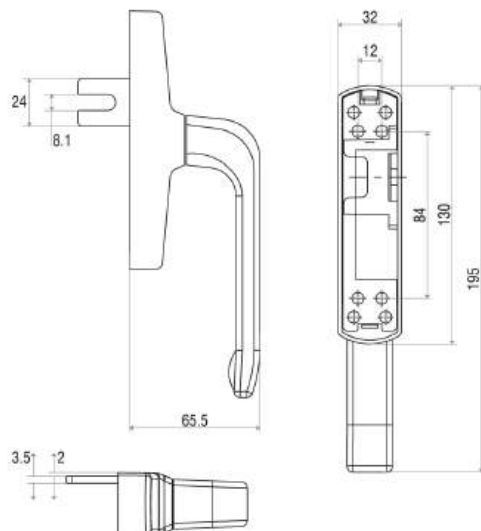

# CASEMENT MULTI POINT HANDLE MP-63-L/H

**Description : Aluminium Multi Point Lock Handle**

| Code                     | Finish               |
|--------------------------|----------------------|
| MP-63-L-DB (Only Base)   | Black Powder Coating |
| MP-63-L-DW (Only Base)   | White Powder Coating |
| MP-63-H-DB (Only Handle) | Black Powder Coating |
| MP-63-H-DW (Only Handle) | White Powder Coating |

**Description : Aluminium Locking Strip**

| Code      | Code       | Code       | Code       |
|-----------|------------|------------|------------|
| MP-01-400 | MP-01-800  | MP-01-1200 | MP-01-1600 |
| MP-01-600 | MP-01-1000 | MP-01-1400 | MP-01-1800 |

Product Drawing

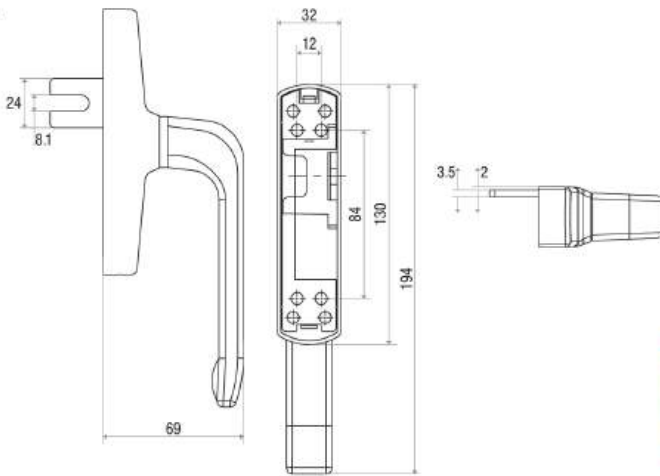

# FLUSH BOLT FB

**Description : Aluminium Flush Bolt**

| Code     | Finish               | Size  |
|----------|----------------------|-------|
| FB-150-B | Black Powder Coating | 150mm |
| FB-150-W | White Powder Coating | 150mm |
| FB-330-B | Black Powder Coating | 330mm |
| FB-330-W | White Powder Coating | 330mm |
| FB-500-B | Black Powder Coating | 500mm |
| FB-500-W | White Powder Coating | 500mm |

Product Drawing

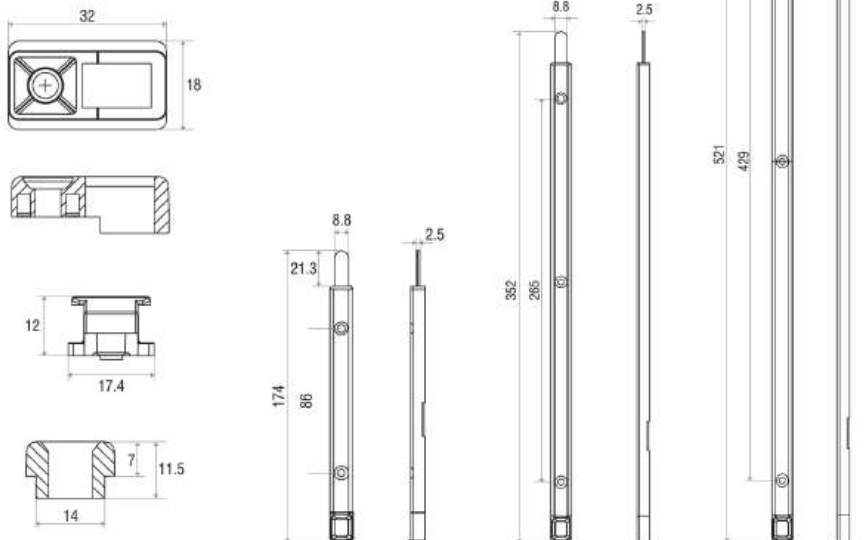

**SP-27**

**CASEMENT SINGLE POINT HANDLE**



**Description : Aluminium Single Point Handle**

| Code     | Finish               | L & R |
|----------|----------------------|-------|
| SP-27-RB | Black Powder Coating | Right |
| SP-27-LB | Black Powder Coating | Left  |
| SP-27-RW | White Powder Coating | Right |
| SP-27-LW | White Powder Coating | Left  |

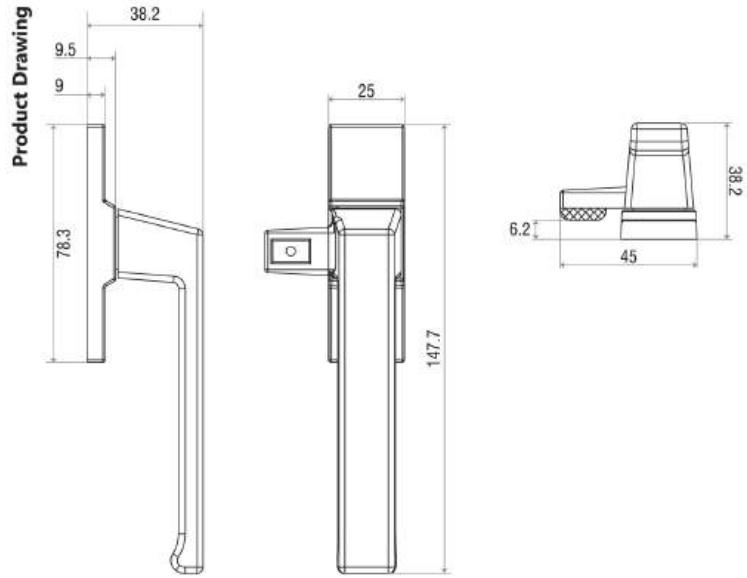

**SP-18**

**CASEMENT SINGLE POINT HANDLE**



**Description : Aluminium Single Point Handle**

| Code     | Finish               | L & R |
|----------|----------------------|-------|
| SP-18-RB | Black Powder Coating | Right |
| SP-18-LB | Black Powder Coating | Left  |
| SP-18-RW | White Powder Coating | Right |
| SP-18-LW | White Powder Coating | Left  |

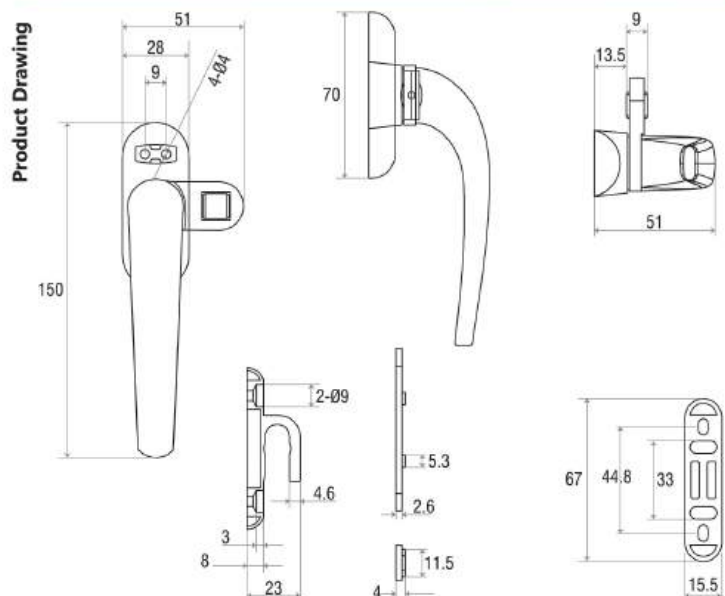

# CASEMENT SINGLE POINT HANDLE

SP-09

**Description : Aluminium Single Point Handle**

| Code     | Finish                | L & R |
|----------|-----------------------|-------|
| SP-09-RB | Black Powder Coating  | Right |
| SP-09-LB | Black Powder Coating  | Left  |
| SP-09-RW | White Powder Coating  | Right |
| SP-09-LW | White Powder Coating  | Left  |
| SP-09-RS | Silver Powder Coating | Right |
| SP-09-LS | Silver Powder Coating | Left  |

Product Drawing

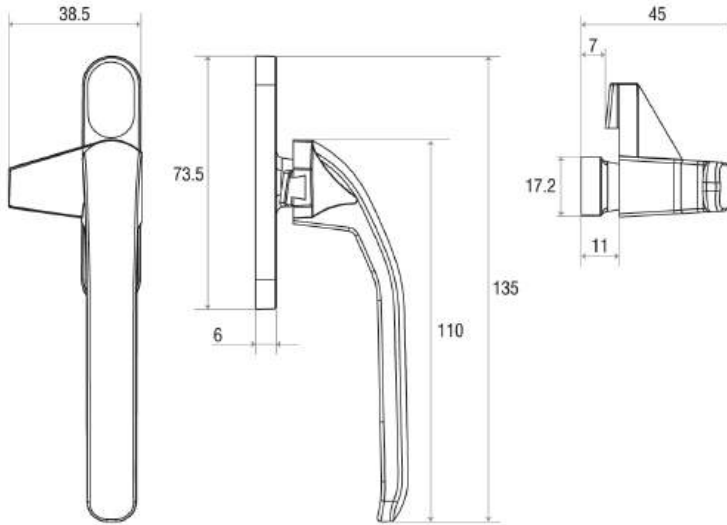

SP-09-RB

# CASEMENT SINGLE POINT HANDLE

SP-09-K

**Description : Aluminium Single Point Handle (Key)**

| Code       | Finish               | L & R |
|------------|----------------------|-------|
| SP-09-K-RB | Black Powder Coating | Right |
| SP-09-K-LB | Black Powder Coating | Left  |
| SP-09-K-RW | White Powder Coating | Right |
| SP-09-K-LW | White Powder Coating | Left  |

Product Drawing

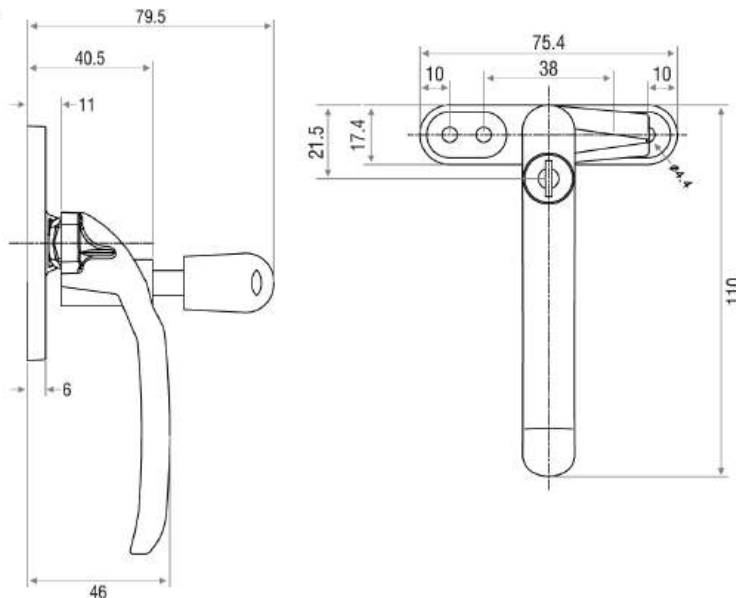

SP-09-K-RB

**SP-01**

**CASEMENT SINGLE POINT HANDLE**



**Description : Aluminium Single Point Handle**

| Code     | Finish                | L & R |
|----------|-----------------------|-------|
| SP-01-RB | Black Powder Coating  | Right |
| SP-01-LB | Black Powder Coating  | Left  |
| SP-01-RW | White Powder Coating  | Right |
| SP-01-LW | White Powder Coating  | Left  |
| SP-01-RS | Silver Powder Coating | Right |
| SP-01-LS | Silver Powder Coating | Left  |

Product Drawing

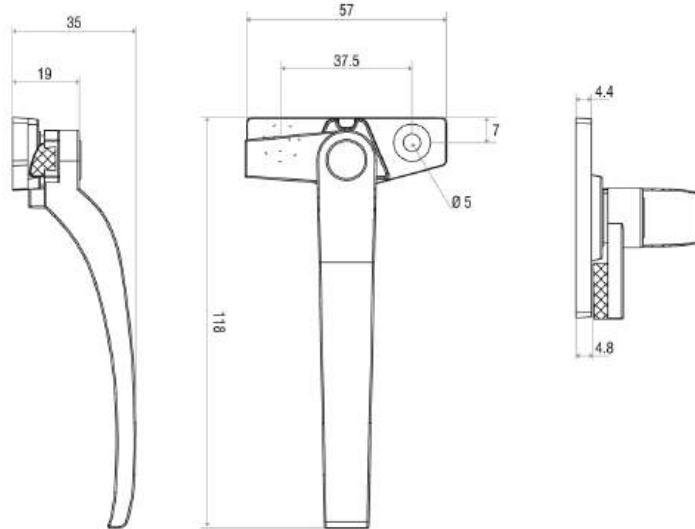

**WH-52**

**HINGE**



**Description : Aluminium Hinges**

| Code    | Finish               |
|---------|----------------------|
| WH-52-B | Black Powder Coating |
| WH-52-W | White Powder Coating |

Product Drawing

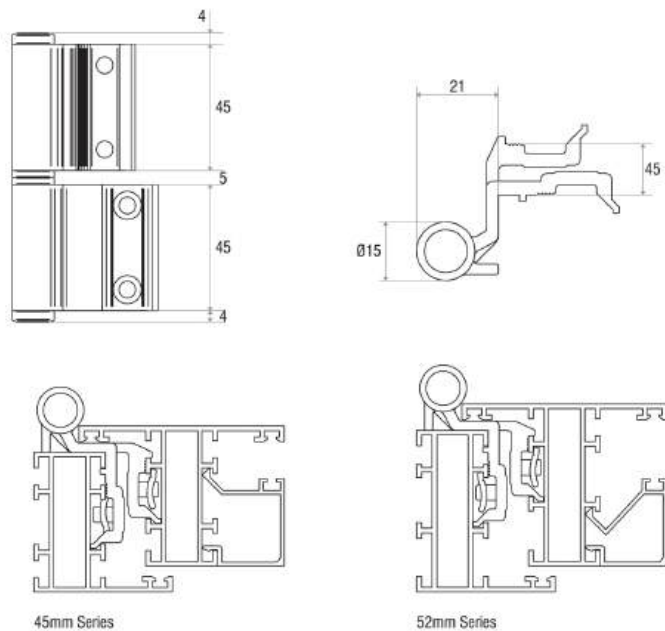



HINGE **WH-40**

**Description : Aluminium Hinges**

| Code    | Finish               |
|---------|----------------------|
| WH-40-B | Black Powder Coating |
| WH-40-W | White Powder Coating |

Product Drawing

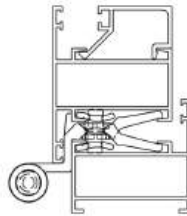
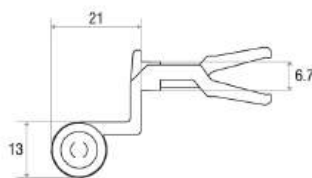
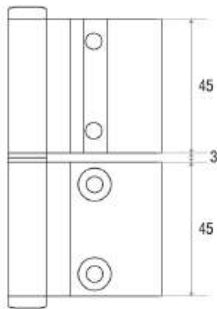

40mm Series

WH-40-B



HINGE (FOR DOOR) **WH-40D**

**Description : Aluminium Hinges (3 Wing for Door)**

| Code     | Finish               |
|----------|----------------------|
| WH-40D-B | Black Powder Coating |
| WH-40D-W | White Powder Coating |

Product Drawing

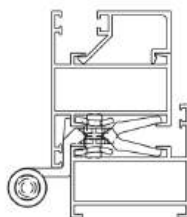
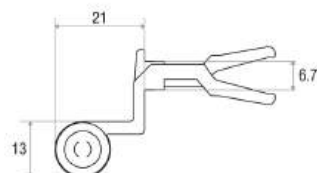
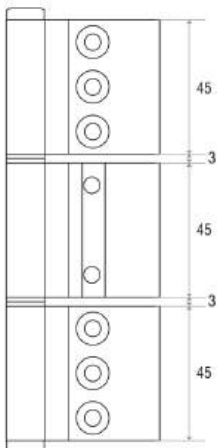

40mm Series

WH-40D-B



**WH-EU**

**HINGE (EURO GROOVE)**



**Description : Aluminium Hinges (Euro Groove)**

| Code    | Finish               |
|---------|----------------------|
| WH-EU-B | Black Powder Coating |
| WH-EU-W | White Powder Coating |

Product Drawing

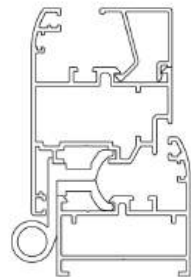
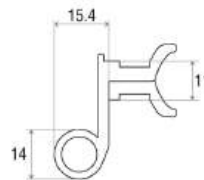
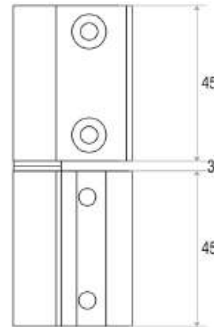

Euro Groove

**WH-EU-D**

**HINGE (HEAVY DUTY)**



**Description : Aluminium Hinges (Heavy Duty for Door)**

| Code      | Finish               |
|-----------|----------------------|
| WH-EU-D-B | Black Powder Coating |
| WH-EU-D-W | White Powder Coating |

Product Drawing

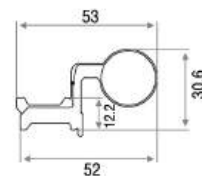
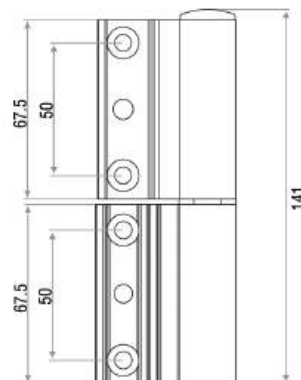

# CENTER POINT LOCK

CP-303

**Description : Aluminium Center Point Lock**

| Code     | Finish               |
|----------|----------------------|
| CP-303-B | Black Powder Coating |
| CP-303-W | White Powder Coating |

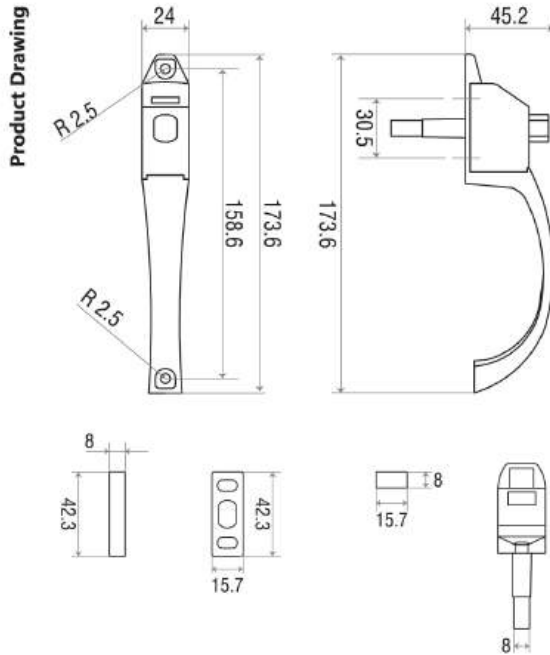

CP-303-B

# CENTER POINT LOCK

CP-303-K

**Description : Aluminium Center Point Lock (Key)**

| Code      | Finish               |
|-----------|----------------------|
| CP-303-KB | Black Powder Coating |
| CP-303-KW | White Powder Coating |

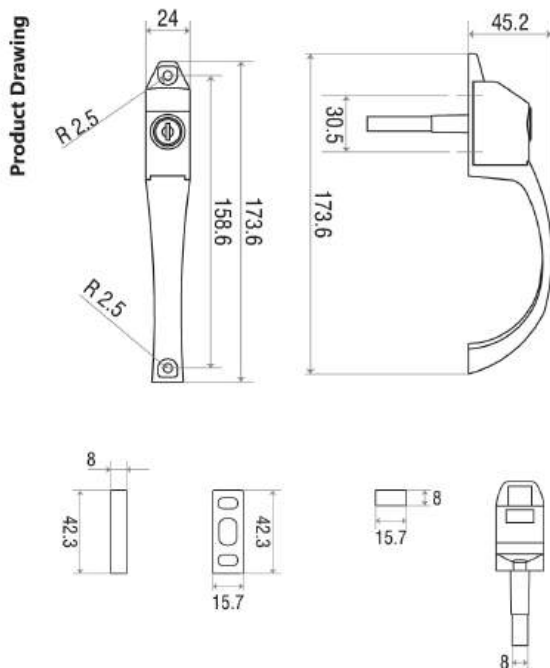

CP-303-KB

**SS-202-FS**

**FRICITION STAY (GRADE SS 202)**

**Description : Stainless Steel Friction Stay (Grade 202)**

| Code         | Size  | Weight Capacity | Bars | Bars Thickness | Openable Degree |
|--------------|-------|-----------------|------|----------------|-----------------|
| SS-202-FS-08 | 200mm | 12 Kgs.         | 4    | 2mm            | 65°             |
| SS-202-FS-10 | 250mm | 14 Kgs.         | 4    | 2mm            | 90°             |
| SS-202-FS-12 | 300mm | 16 Kgs.         | 4    | 2mm            | 90°             |
| SS-202-FS-14 | 350mm | 18 Kgs.         | 4    | 2mm            | 90°             |
| SS-202-FS-16 | 400mm | 22 Kgs.         | 4    | 2.5mm          | 90°             |
| SS-202-FS-18 | 450mm | 24 Kgs.         | 4    | 3mm            | 90°             |
| SS-202-FS-20 | 500mm | 26 Kgs.         | 5    | 3mm            | 65°             |
| SS-202-FS-24 | 600mm | 30 Kgs.         | 6    | 3mm            | 55°             |
| SS-202-FS-28 | 700mm | 85 Kgs.         | 7    | 3mm            | 30°             |
| SS-202-FS-30 | 750mm | 100 Kgs.        | 7    | 3mm            | 30°             |
| SS-202-FS-36 | 900mm | 120 Kgs.        | 7    | 3mm            | 30°             |

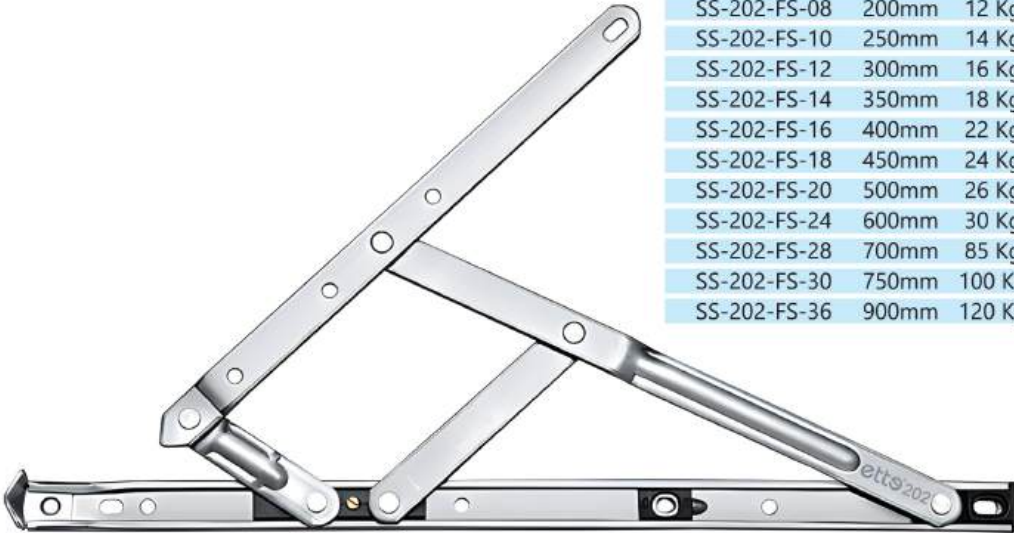

**Product Drawing**

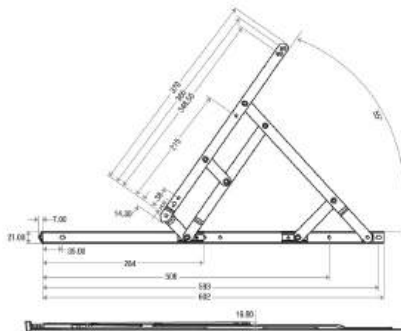
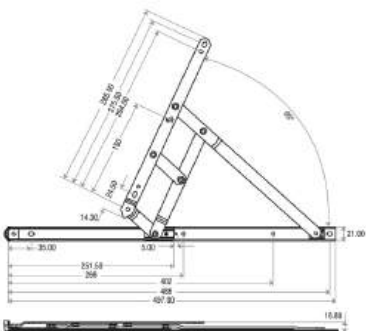
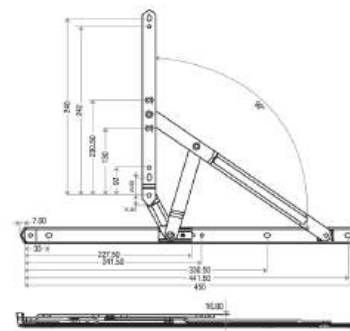
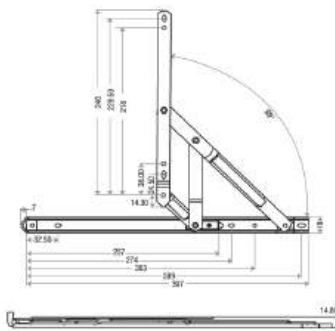
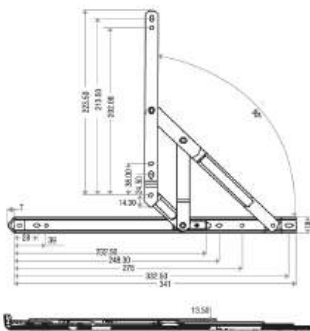
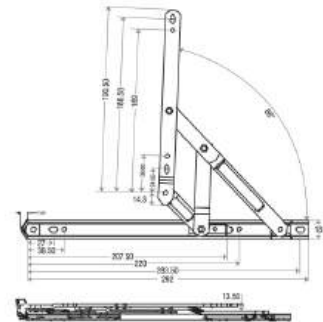
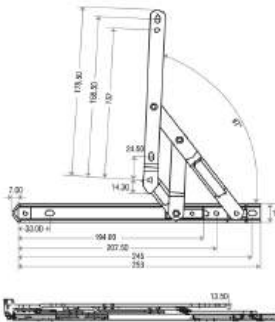
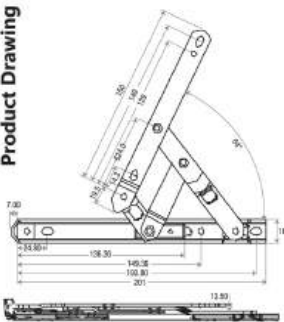

# FRICTION STAY (GRADE SS 304)

## SS-304-FS

Description : Stainless Steel Friction Stay (Grade 304)

| Code         | Size  | Weight Capacity | Bars | Bars Thickness | Openable Degree |
|--------------|-------|-----------------|------|----------------|-----------------|
| SS-304-FS-08 | 200mm | 12 Kgs.         | 4    | 2mm            | 65°             |
| SS-304-FS-10 | 250mm | 14 Kgs.         | 4    | 2mm            | 90°             |
| SS-304-FS-12 | 300mm | 16 Kgs.         | 4    | 2mm            | 90°             |
| SS-304-FS-14 | 350mm | 18 Kgs.         | 4    | 2mm            | 90°             |
| SS-304-FS-16 | 400mm | 22 Kgs.         | 4    | 2.5mm          | 90°             |
| SS-304-FS-18 | 450mm | 24 Kgs.         | 4    | 3mm            | 90°             |
| SS-304-FS-20 | 500mm | 26 Kgs.         | 5    | 3mm            | 65°             |
| SS-304-FS-24 | 600mm | 30 Kgs.         | 6    | 3mm            | 55°             |

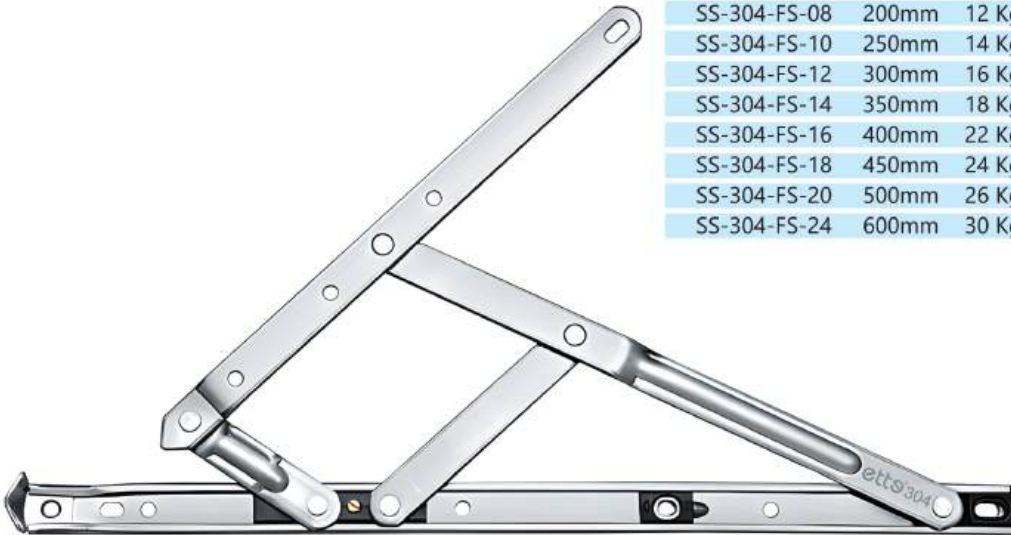

Product Drawing

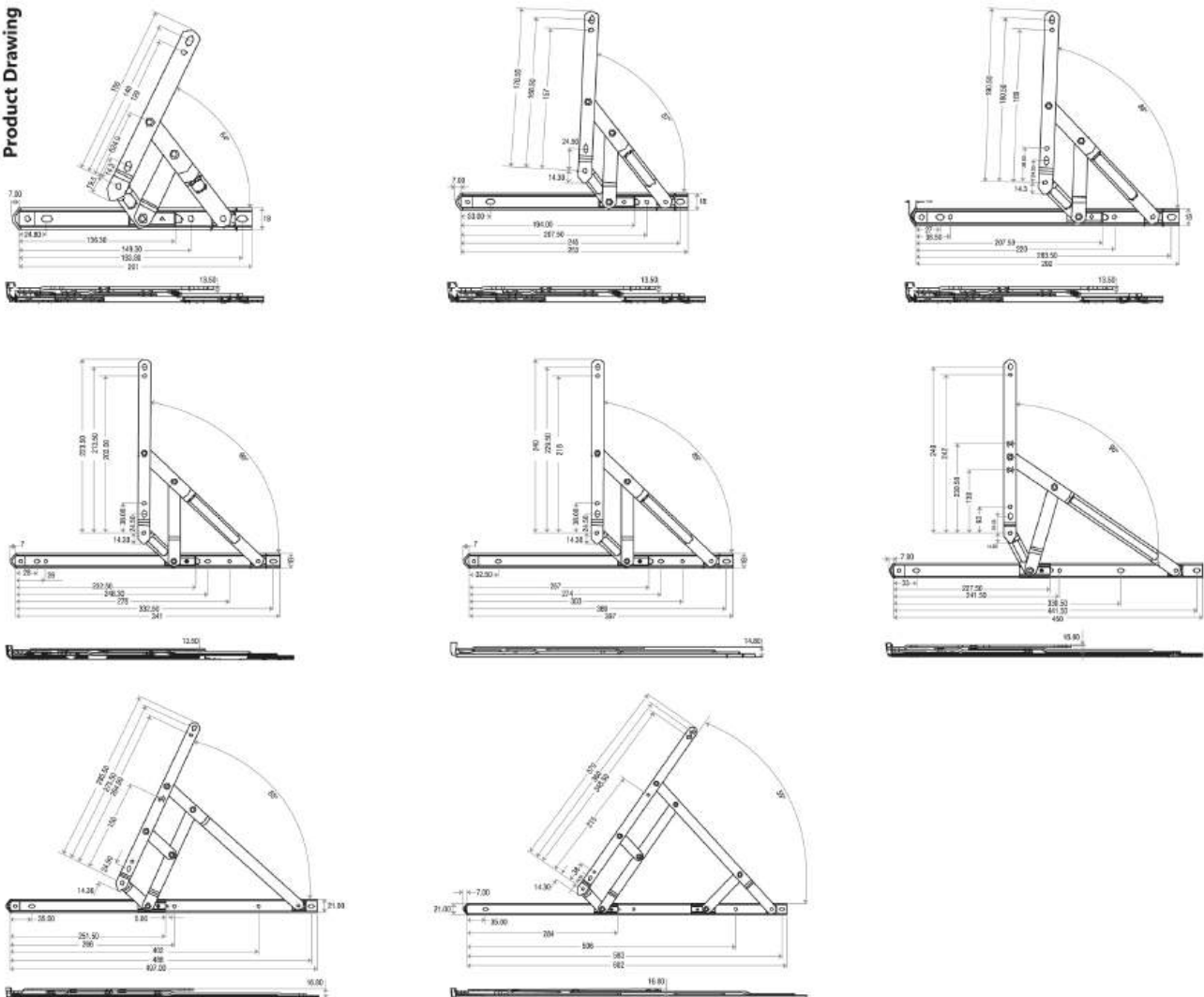

# SS-202-EURO-FS FRICTION STAY (EURO GROOVE • GRADE SS 202)

Description : Stainless Steel Friction Stay (Euro Groove • Grade 202)

| Code              | Size  | Weight Capacity | Bars | Bars Thickness | Openable Degree |
|-------------------|-------|-----------------|------|----------------|-----------------|
| SS-202-EURO-FS-10 | 250mm | 12 Kgs.         | 4    | 2.5mm          | 90°             |
| SS-202-EURO-FS-12 | 300mm | 15 Kgs.         | 4    | 2.5mm          | 90°             |
| SS-202-EURO-FS-14 | 350mm | 20 Kgs.         | 4    | 2.5mm          | 90°             |
| SS-202-EURO-FS-16 | 400mm | 23 Kgs.         | 4    | 2.5mm          | 90°             |

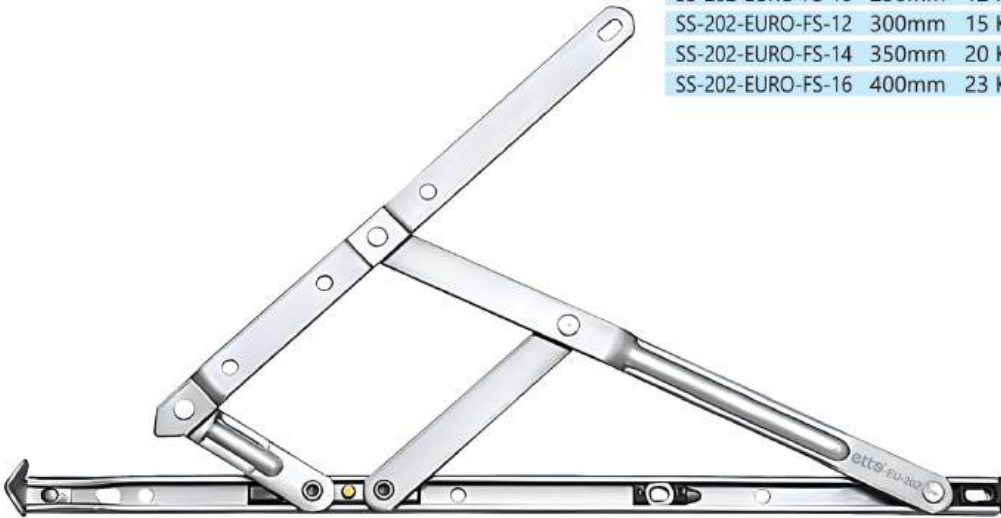

Product Drawing

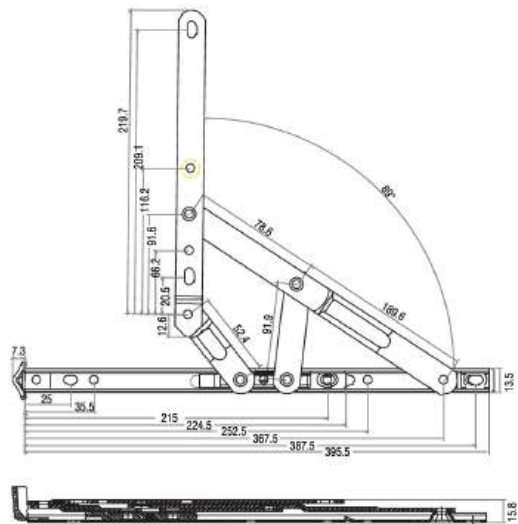
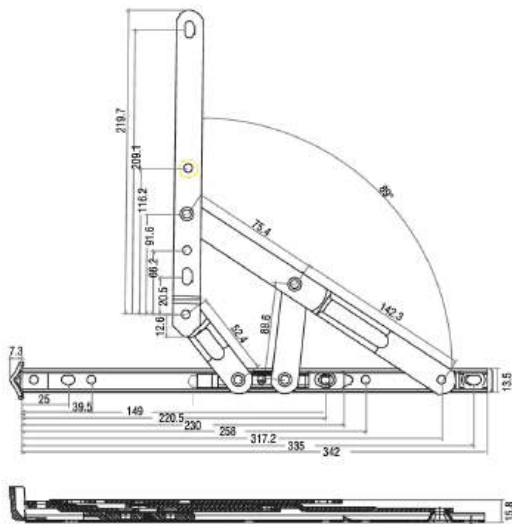
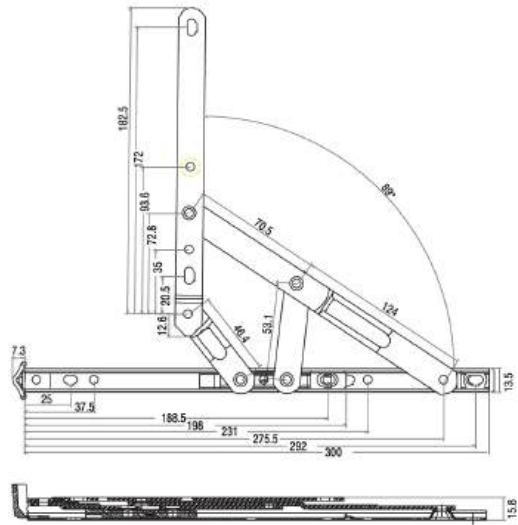
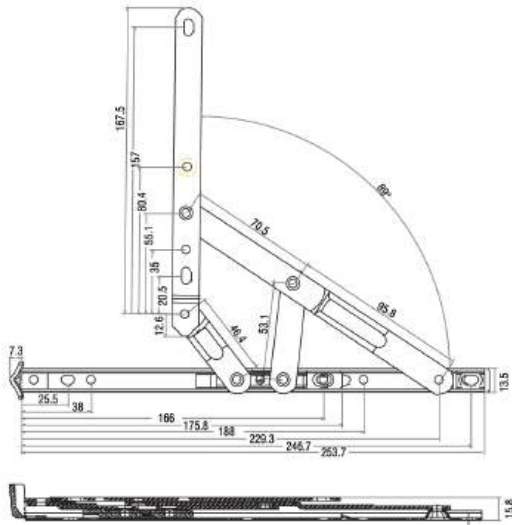

# FRICTION STAY (EURO GROOVE • GRADE SS 304) **SS-304-EURO-FS**

Description : Stainless Steel Friction Stay (Euro Groove • Grade 304)

| Code              | Size  | Weight Capacity | Bars | Bars Thickness | Openable Degree |
|-------------------|-------|-----------------|------|----------------|-----------------|
| SS-304-EURO-FS-10 | 250mm | 12 Kgs.         | 4    | 2.5mm          | 90°             |
| SS-304-EURO-FS-12 | 300mm | 15 Kgs.         | 4    | 2.5mm          | 90°             |
| SS-304-EURO-FS-14 | 350mm | 20 Kgs.         | 4    | 2.5mm          | 90°             |
| SS-304-EURO-FS-16 | 400mm | 23 Kgs.         | 4    | 2.5mm          | 90°             |

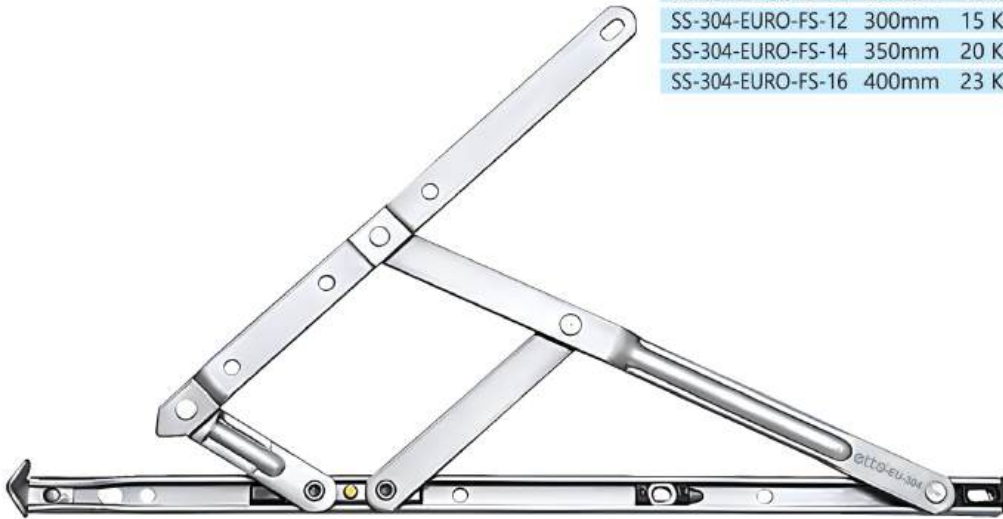

Product Drawing

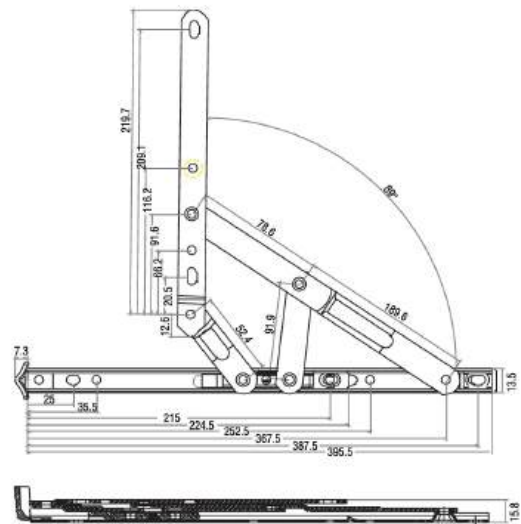
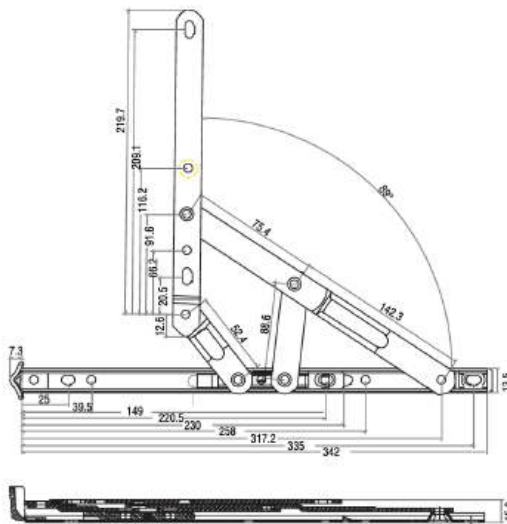
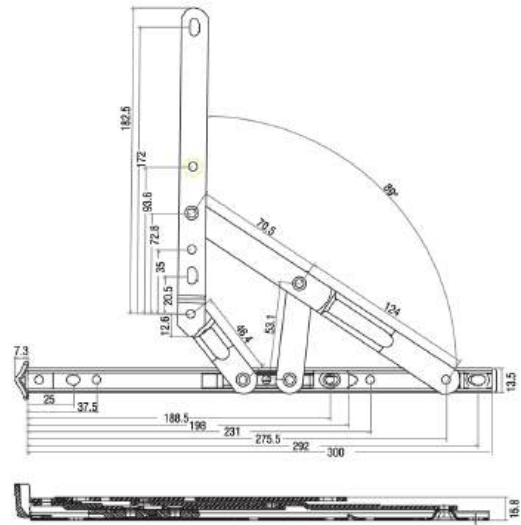
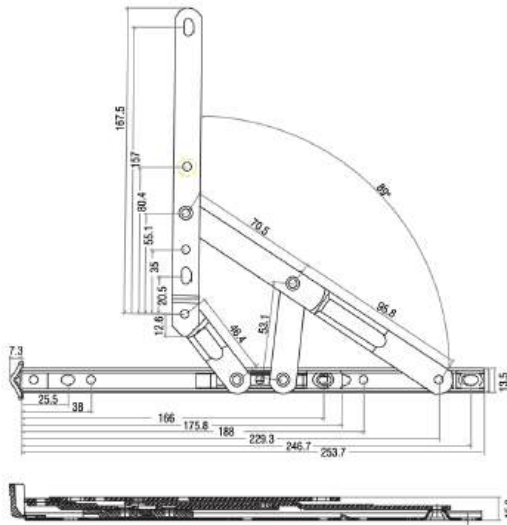

**AS-202 ARM STAY (EURO GROOVE • GRADE SS 202)**

**Description : Stainless Steel Stay Arm (Euro Groove • Grade 202)**

| Code      | Size  |
|-----------|-------|
| AS-202-10 | 250mm |
| AS-202-12 | 300mm |

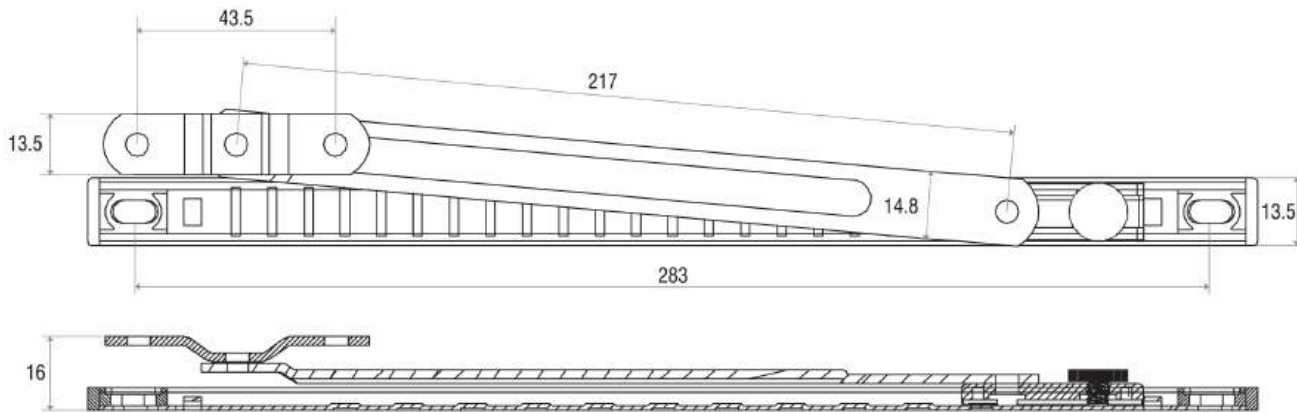
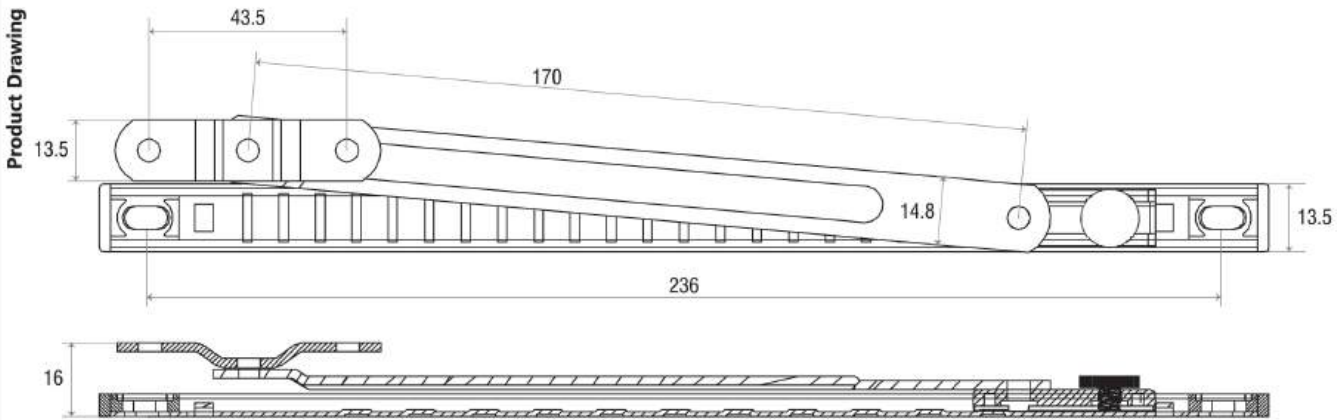



ARM STAY (EURO GROOVE • GRADE SS 304)

AS-304

Description : Stainless Steel Stay Arm (Euro Groove • Grade 304)

| Code      | Size  |
|-----------|-------|
| AS-304-10 | 250mm |
| AS-304-12 | 300mm |

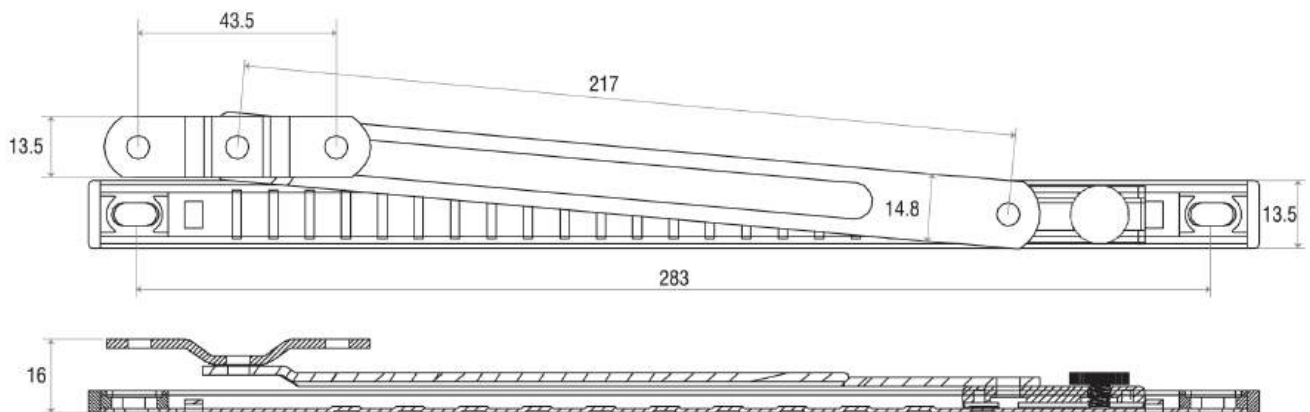
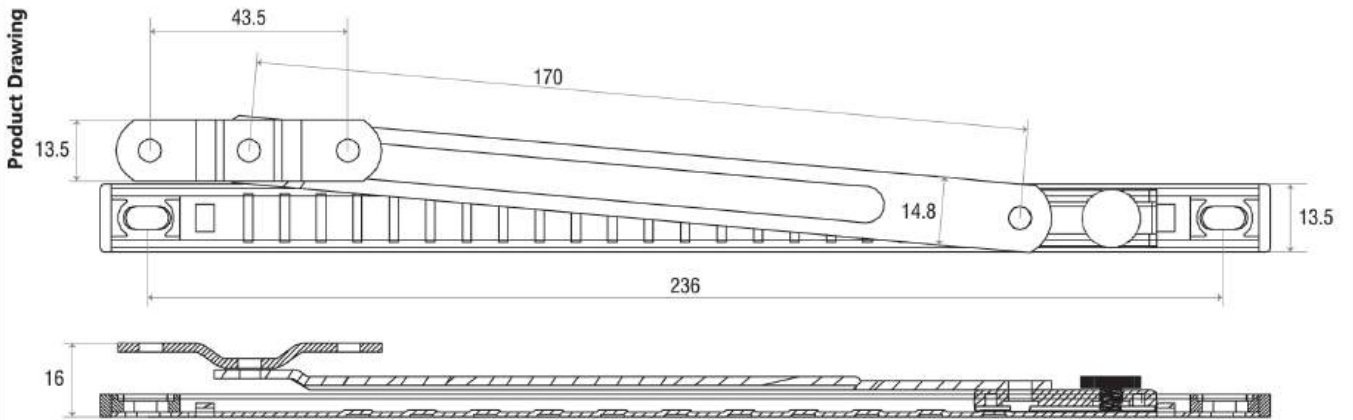
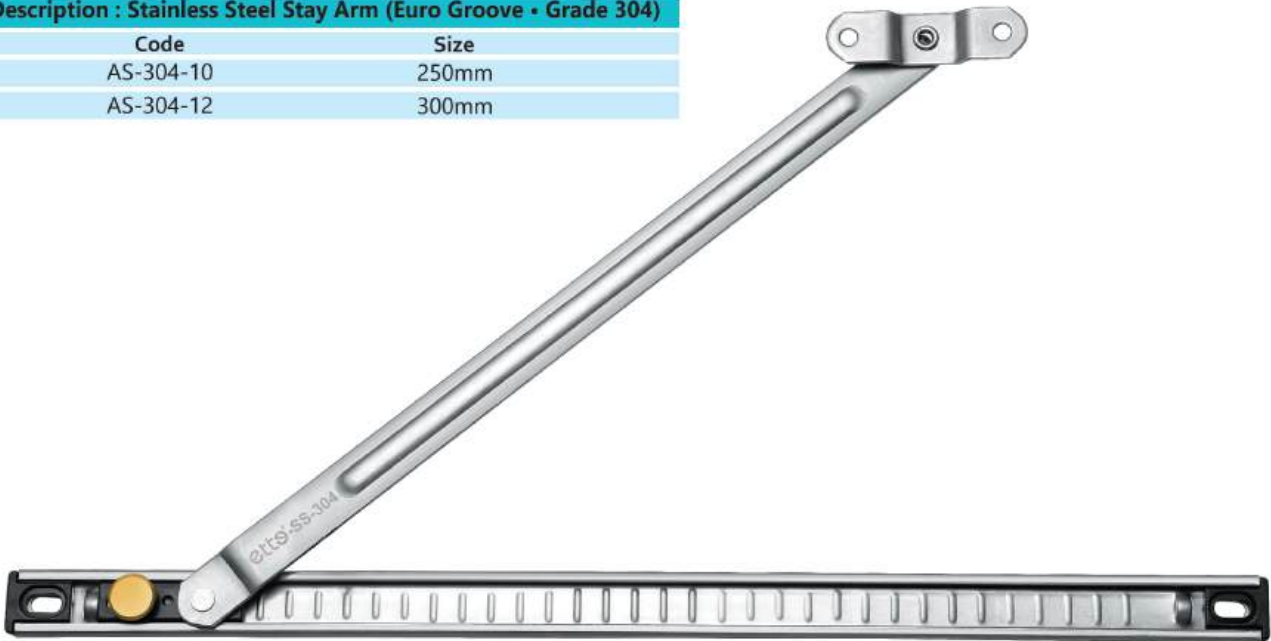

**MH-25**

**MORTISE HANDLE**



MH-25-BL

**Description : Zinc Mortise Handle**

| Code     | Finish               |
|----------|----------------------|
| MH-25-BL | Black Powder Coating |
| MH-25-WH | White Powder Coating |

Product Drawing

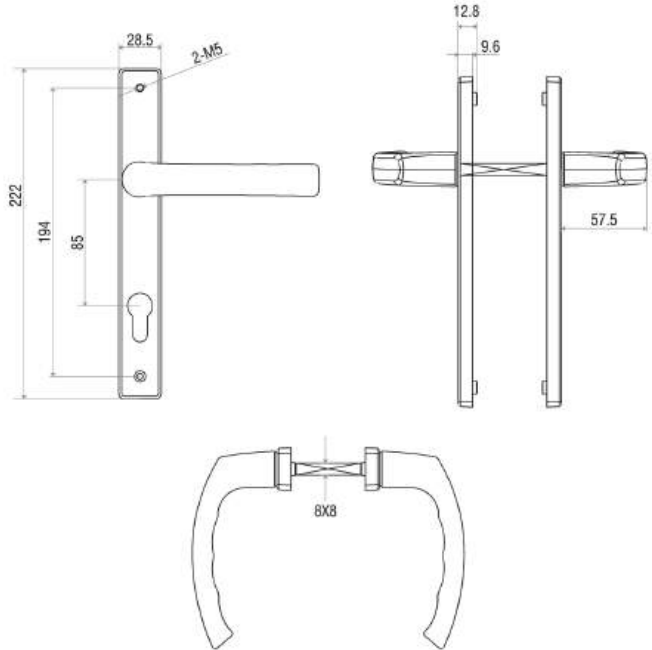

**MH-30**

**MORTISE HANDLE**



MH-30-BL

**Description : Aluminium Mortise Handle**

| Code     | Finish               |
|----------|----------------------|
| MH-30-BL | Black Powder Coating |
| MH-30-WH | White Powder Coating |

Product Drawing

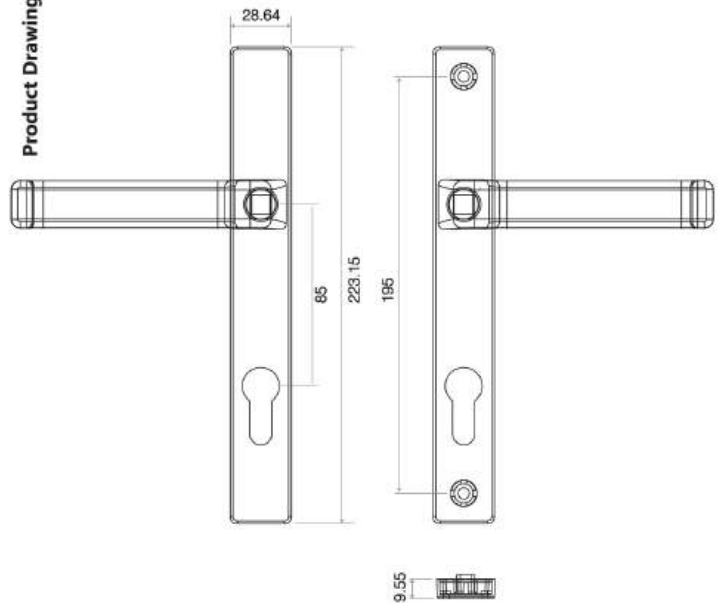

# LOCK BODY & PLATE

## LB & PLT

### Description : Mortise Lock Body & SS Plate

| Code      | Finish | Hole Distance |
|-----------|--------|---------------|
| LB-20     | SS     | 20mm          |
| LB-25     | SS     | 25mm          |
| LB-30     | SS     | 30mm          |
| LB-35     | SS     | 35mm          |
| LB-PLT-01 | SS     |               |
| LB-PLT-02 | SS     |               |

Product Drawing

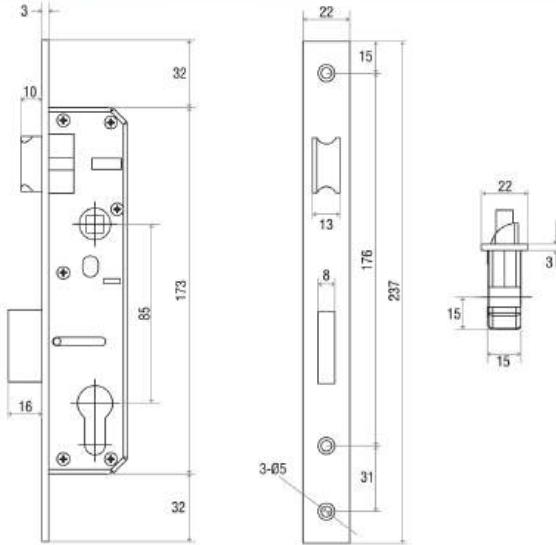

# MULTI POINT LOCK BODY WITH PLATE

## LB-MP-PLT

### Description : Multi Point Lock Body & SS Plate

| Code        | Finish | Hole Distance |
|-------------|--------|---------------|
| LB-MP-30    | SS     | 30mm          |
| LB-MP-35    | SS     | 35mm          |
| LB-PLT-01   | SS     |               |
| LB-PLT-02   | SS     |               |
| MP-LK-ACC-1 | SN     | Accessories   |

Product Drawing

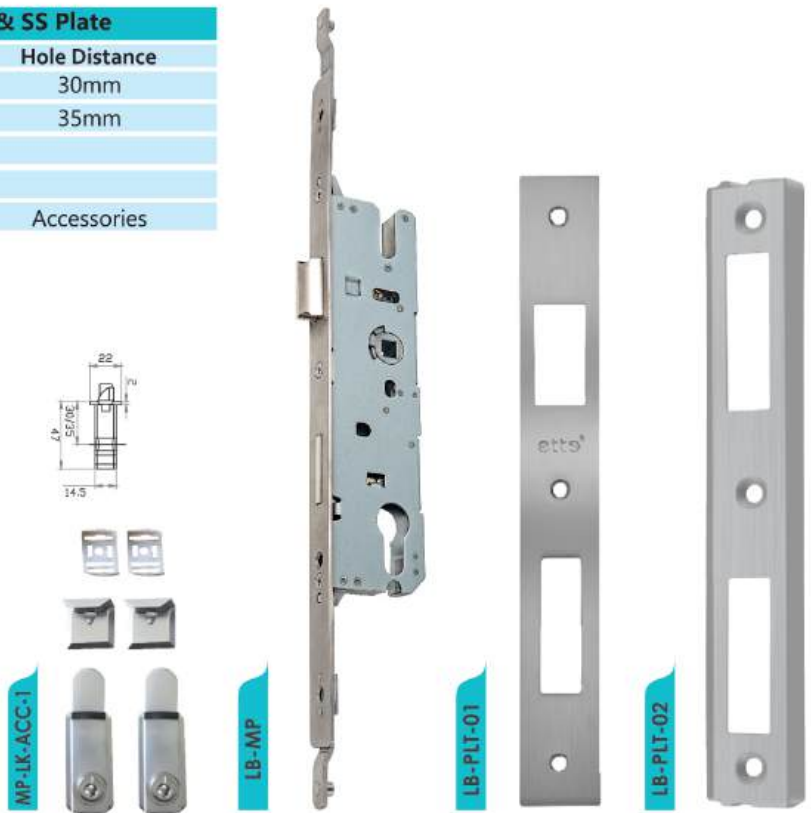
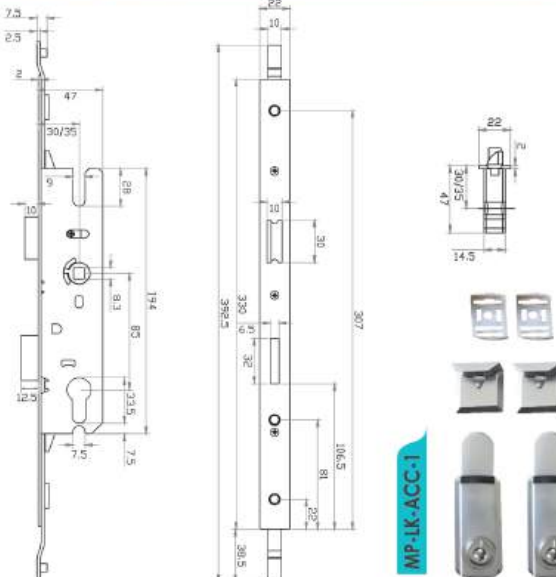

**MH-25-D**

**MORTISE HANDLE (DUMMY)**



MH-25-D-BL

**Description : Zinc Mortise Handle (Dummy)**

| Code       | Finish               |
|------------|----------------------|
| MH-25-D-BL | Black Powder Coating |
| MH-25-D-WH | White Powder Coating |

Product Drawing

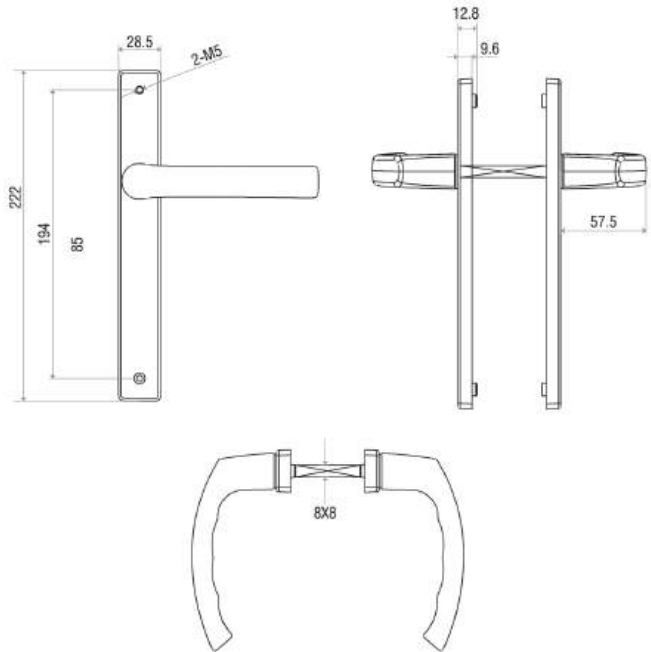

**LB-D & PLT-D**

**LOCK BODY (DUMMY) & PLATE (DUMMY)**



LB-25-D



LB-PLT-D

**Description : Mortise Lock Body (Dummy) & SS Plate (Dummy)**

| Code     | Finish |
|----------|--------|
| LB-25-D  | SS     |
| LB-PLT-D | SS     |

Product Drawing

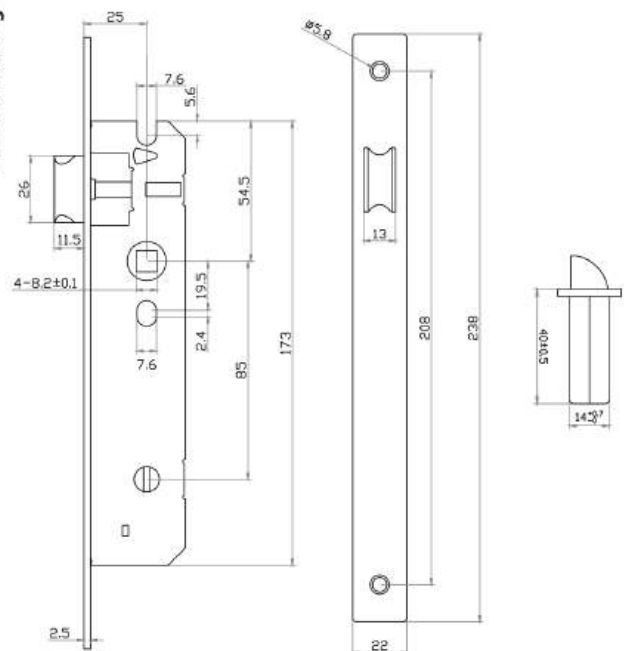

CYLINDER **CY**

Description : Brass Cylinder

| Code            | Finish | Key           | Size |
|-----------------|--------|---------------|------|
| CY-70-KN        | SS     | Key & Knob    | 70mm |
| CY-70-KK        | SS     | Both Side Key | 70mm |
| CY-80-KN        | SS     | Key & Knob    | 80mm |
| CY-80(45+35)-KN | SS     | Key & Knob    | 80mm |

Product Drawing

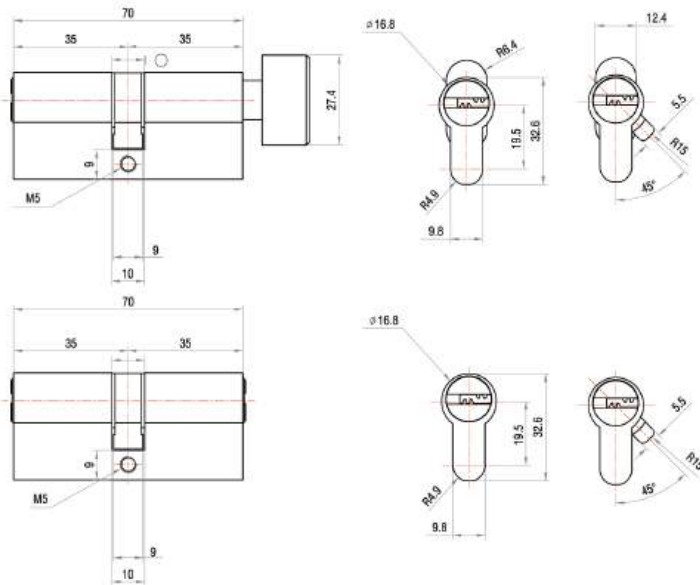

CY-70-KN

HANDLE **HN-80**

Description : Aluminium Handle

| Code    | Finish               |
|---------|----------------------|
| HN-80-B | Black Powder Coating |
| HN-80-W | White Powder Coating |

Product Drawing

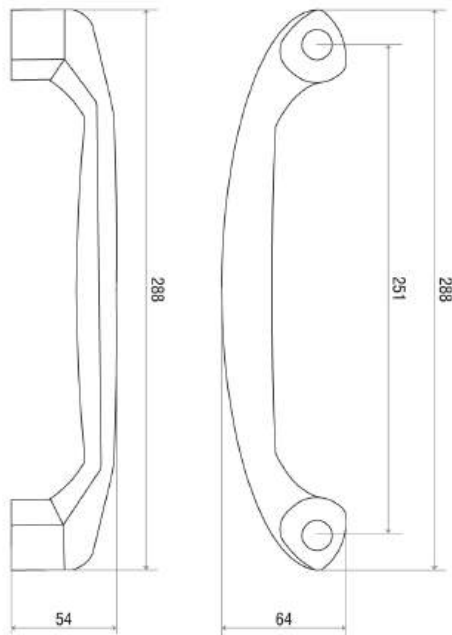

HN-80-NH



SFD

SLIDING FOLDING DOOR

SFD-101-B



SFD-102-B

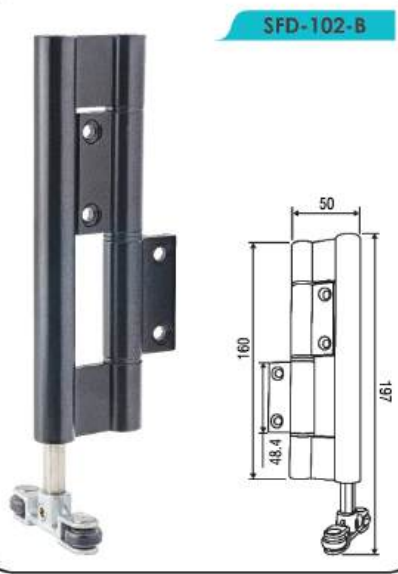

SFD-103-B



SFD-104-B



SFD-105-B



SFD-106-B

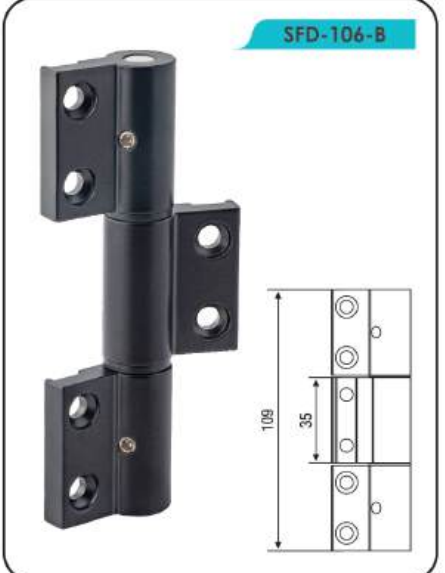

SFD-MP-107-B



SFD-TR-108

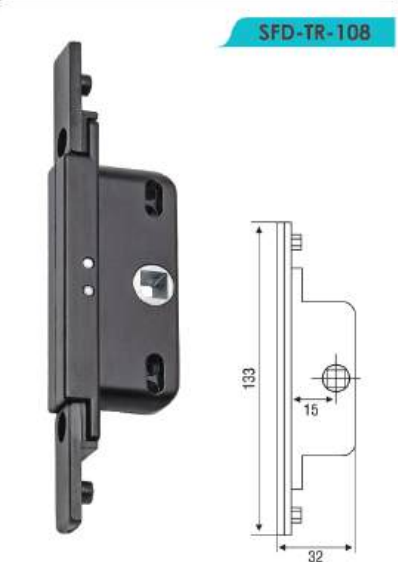

SFD-ALU-1200

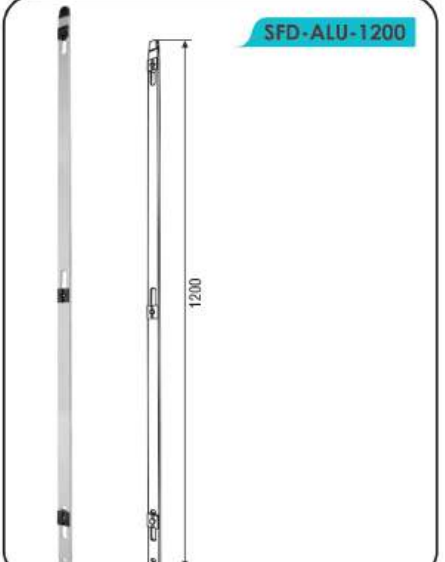

## SLIDING FOLDING DOOR

SFD

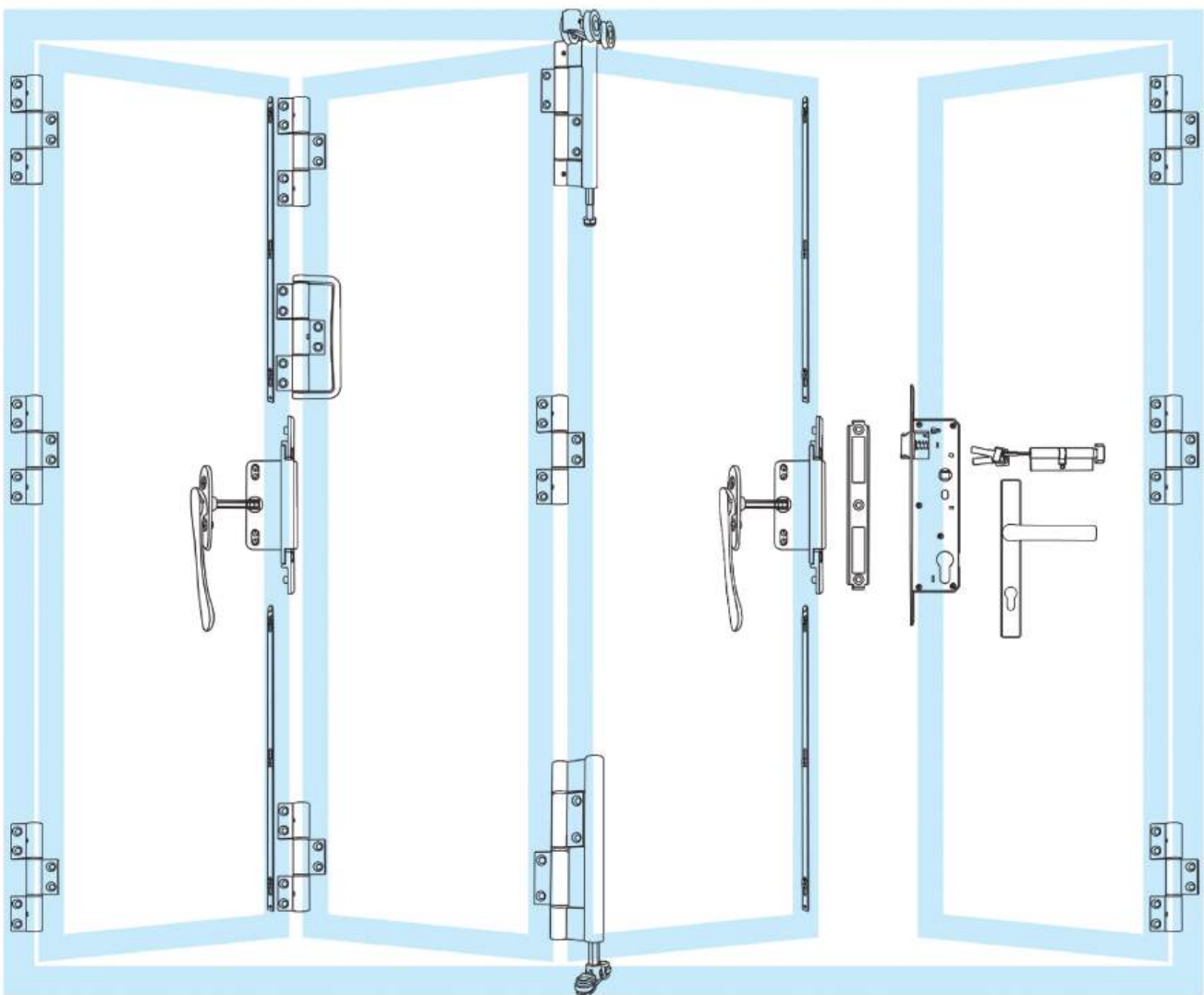

## Description : Sliding Folding Door Accessories

| Product Name                      | Code           | Finish      | Qty (3+1) | Qty (4+1) | Qty (2+2) |
|-----------------------------------|----------------|-------------|-----------|-----------|-----------|
| Double Side Top Hanging Roller    | SFD-101        | Black/White | 1         | 1         | 0         |
| Double Side Bottom Guide Roller   | SFD-102        | Black/White | 1         | 1         | 0         |
| Single Side Top Hanging Roller    | SFD-103        | Black/White | 0         | 1         | 2         |
| Single Side Bottom Guide Roller   | SFD-104        | Black/White | 0         | 1         | 2         |
| Handle Hinge                      | SFD-105        | Black/White | 1         | 2         | 2         |
| Door Hinge                        | SFD-106        | Black/White | 9         | 11        | 10        |
| Multi Point Locking Handle        | SFD-MP-107     | Black/White | 2         | 2         | 2         |
| Transmission Case                 | SFD-TR-108     | Black       | 2         | 2         | 2         |
| Aluminium Locking Strip           | SFD-ALU-1200   | Anodise     | 2         | 4         | 4         |
| Flush Bolt                        | FB-500         | Black/White | 2         | 0         | 0         |
| Mortise Handle                    | MH-25/MH-30    | Black/White | 1         | 1         | 0         |
| Lock Body / Multi Point Lock Body | LB-30/LB-MP-30 | SS          | 1         | 1         | 0         |
| Brass Cylinder                    | CY-80          | SS          | 1         | 1         | 0         |
| Lock Body Plate                   | LB-PLT-1/2     | SS          | 1         | 1         | 0         |





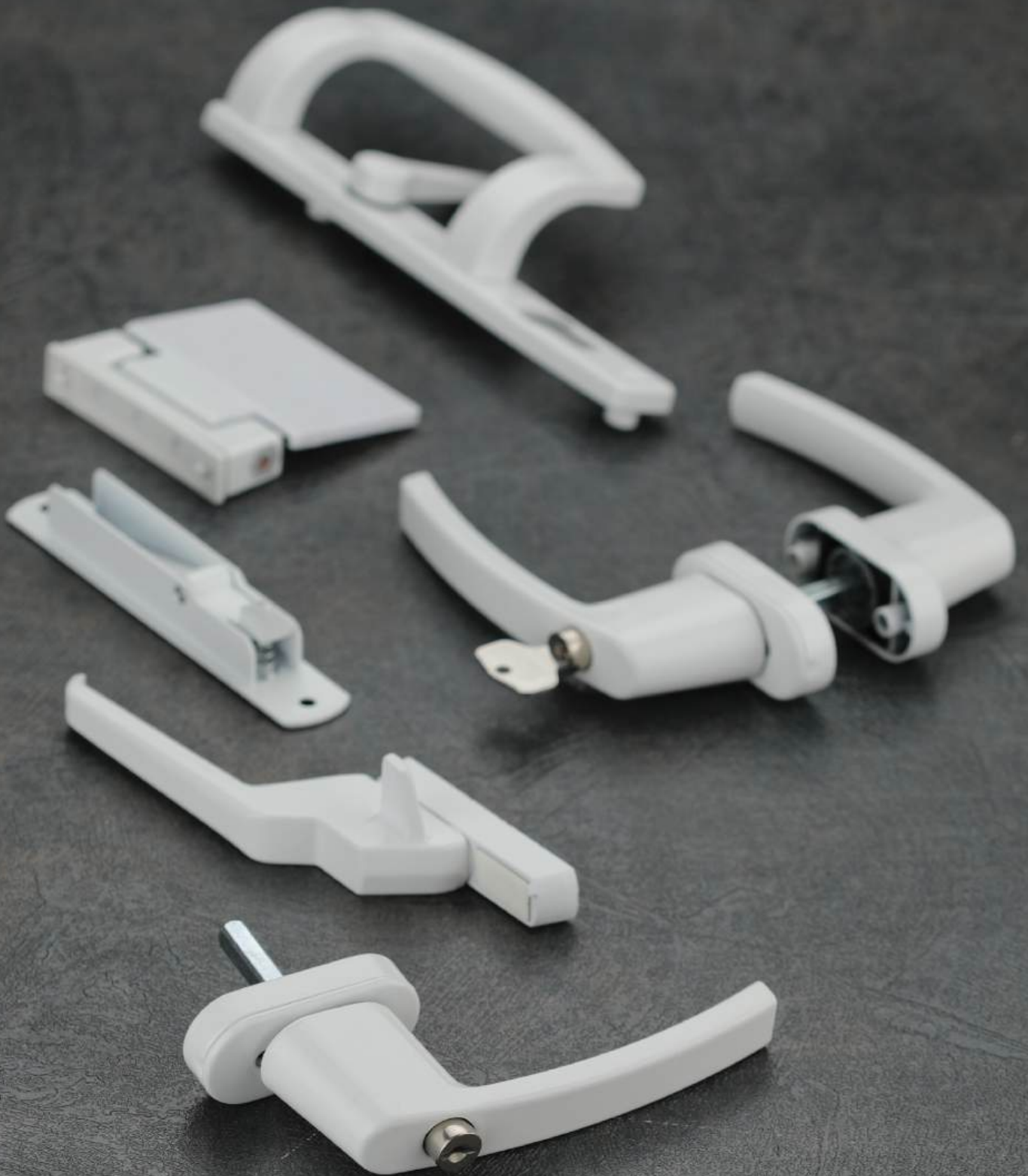

**uPVC SERIES**

**USH-524**

**SLIDING HANDLE**



USH-524-W

**Description : Multi Point Lock Handle**

| Code      | Finish |
|-----------|--------|
| USH-524-B | Black  |
| USH-524-W | White  |

Product Drawing

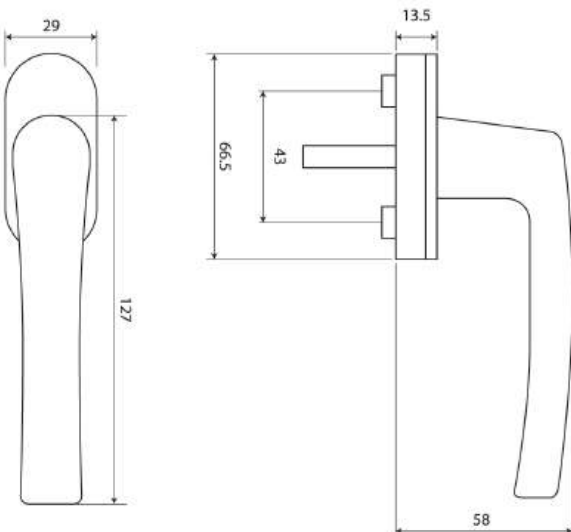

**USH-524-K**

**SLIDING HANDLE**



USH-524-KW

**Description : Multi Point Lock Handle (Key)**

| Code       | Finish |
|------------|--------|
| USH-524-KB | Black  |
| USH-524-KW | White  |

Product Drawing

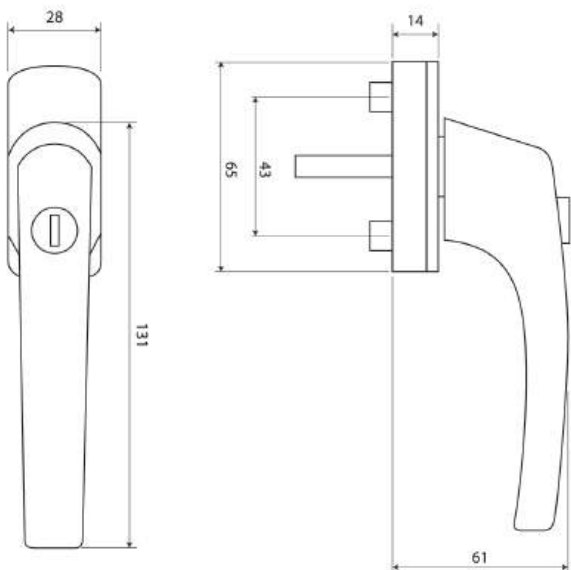

## SLIDING HANDLE

USH-522

## Description : Multi Point Lock Handle

| Code      | Finish |
|-----------|--------|
| USH-522-B | Black  |
| USH-522-W | White  |

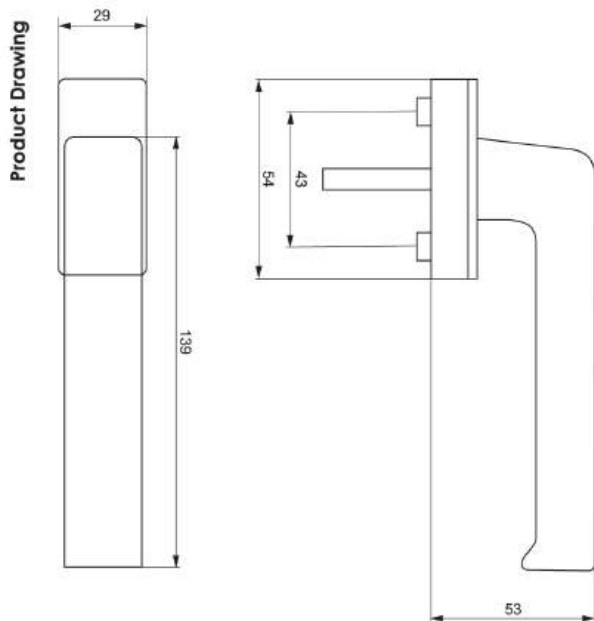

## SLIDING HANDLE

USH-526

## Description : Multi Point Lock Handle

| Code       | Finish | L & R |
|------------|--------|-------|
| USH-526-RB | Black  | Right |
| USH-526-LB | Black  | Left  |
| USH-526-RW | White  | Right |
| USH-526-LW | White  | Left  |

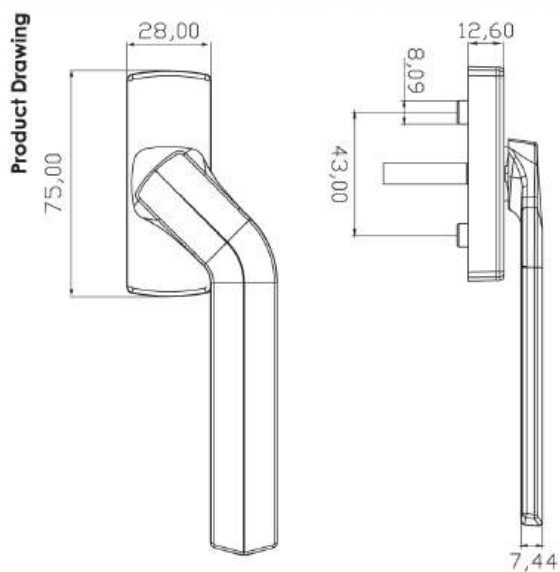

**USH-520**

**SLIDING HANDLE (SHORT NECK)**



**Description : Multi Point Lock Handle**

| Code      | Finish |
|-----------|--------|
| USH-520-B | Black  |
| USH-520-W | White  |

Product Drawing

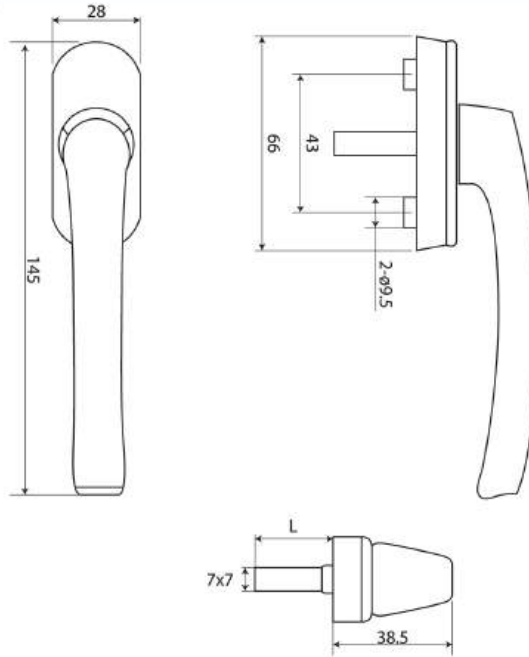

**USH-528**

**SLIDING HANDLE**



**Description : Multi Point Lock Handle**

| Code      | Finish |
|-----------|--------|
| USH-528-B | Black  |
| USH-528-W | White  |

Product Drawing

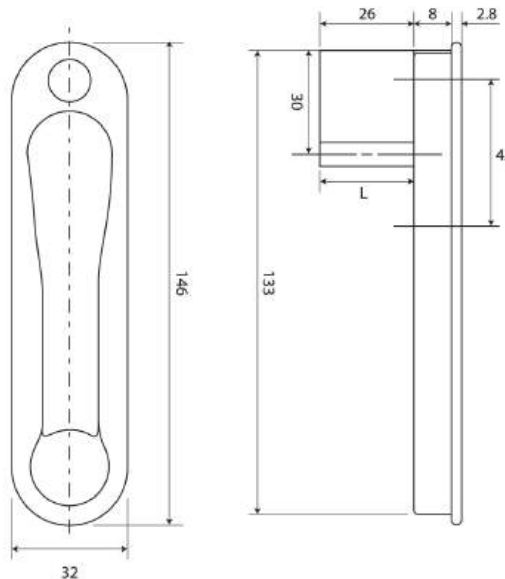

# CONCEAL LOCK **UCL-500-SS**

**Description : Conceal Lock with SS Receiver**

| Code          | Finish | L & R |
|---------------|--------|-------|
| UCL-500-SS-RW | White  | Right |
| UCL-500-SS-LW | White  | Left  |

Product Drawing

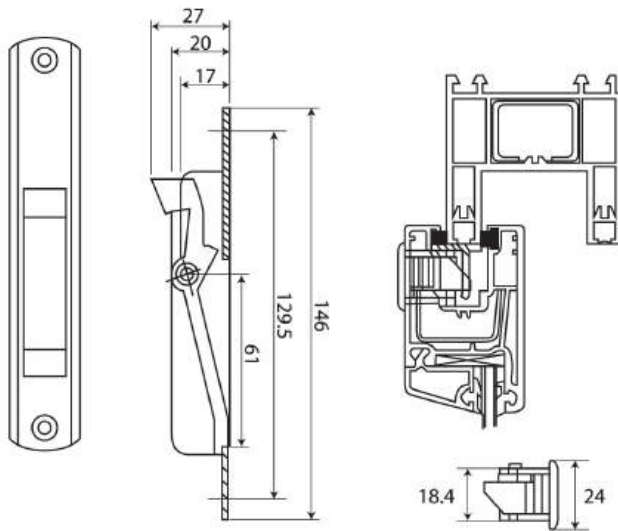

UCL-500-SS



Stainless Steel Receiver



# COCKSPURE HANDLE **UCH-504**

**Description : Single Point Handle**

| Code       | Finish | L & R |
|------------|--------|-------|
| UCH-504-RW | White  | Right |
| UCH-504-LW | White  | Left  |

Product Drawing

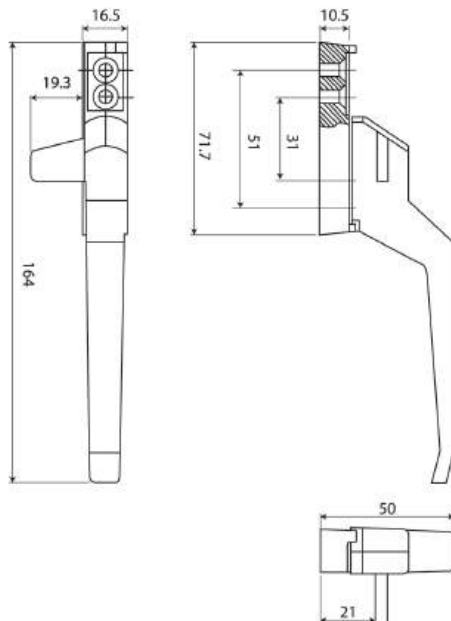

UCH-504-RW



**UCH-512**

## CASEMENT HANDLE

**UCH-512-W**
**Description : Multi Point Lock Handle**

| Code      | Finish |
|-----------|--------|
| UCH-512-W | White  |

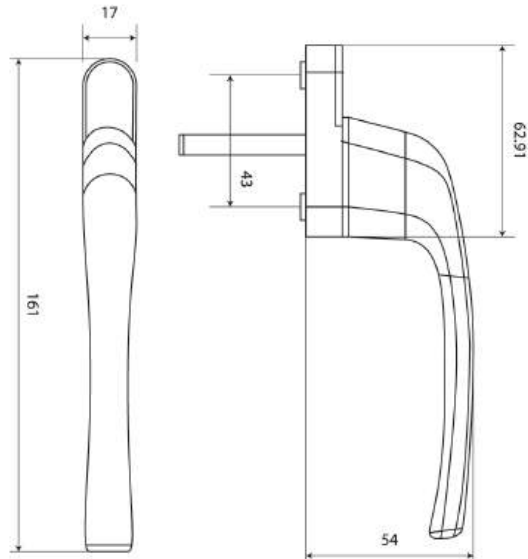
**Product Drawing**

**UCH-512-K**

## CASEMENT HANDLE

**UCH-512-KW**
**Description : Multi Point Lock Handle (Key)**

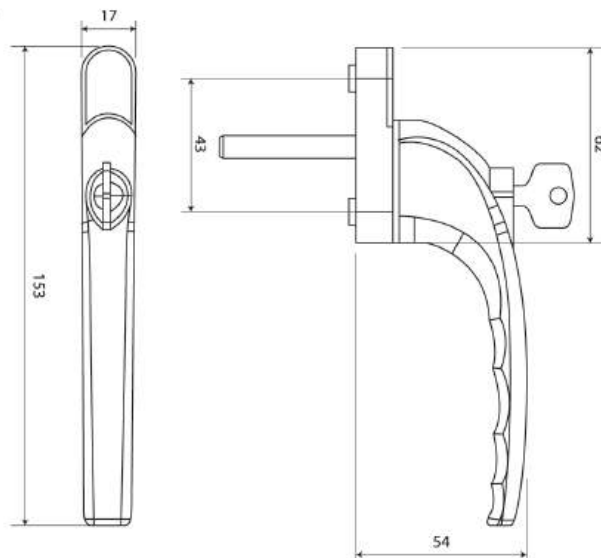
| Code       | Finish |
|------------|--------|
| UCH-512-KW | White  |

**Product Drawing**

# CASEMENT HANDLE

**UCH-508**

**Description : Multi Point Lock Handle**

| Code      | Finish |
|-----------|--------|
| UCH-508-W | White  |

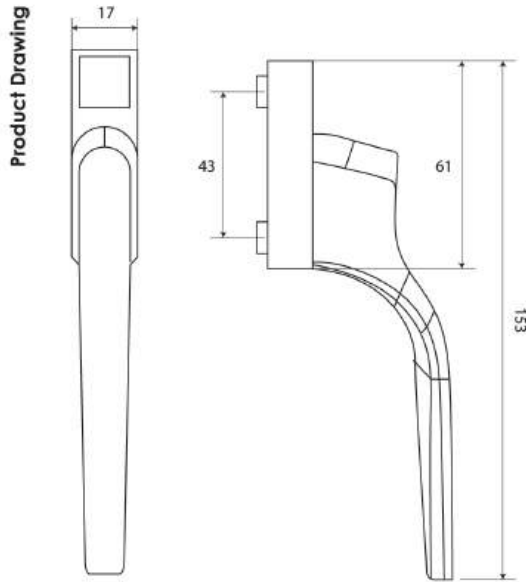

UCH-508-W

# CASEMENT HANDLE

**UCH-516**

**Description : Multi Point Lock Handle (Key)**

| Code        | Finish | L & R |
|-------------|--------|-------|
| UCH-516-RKW | White  | Right |
| UCH-516-LKW | White  | Left  |

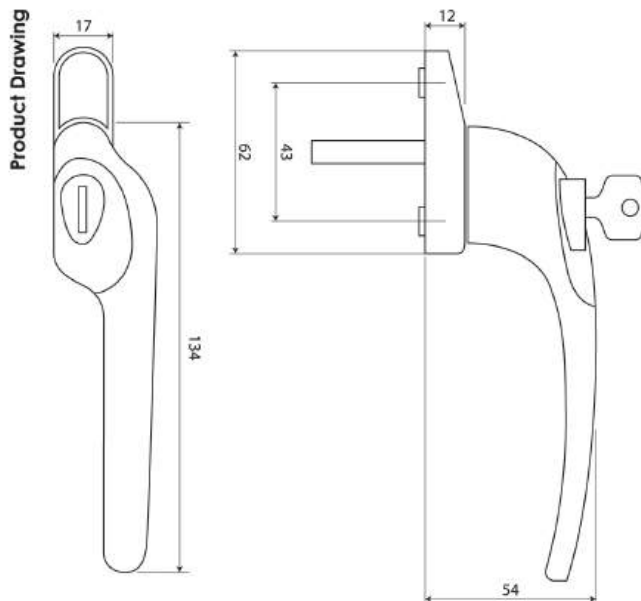

UCH-516-RKW

**UDDH-532 DOOR HANDLE**



| Description : Both Side Handle |        |
|--------------------------------|--------|
| Code                           | Finish |
| UDDH-532-B                     | Black  |
| UDDH-532-W                     | White  |

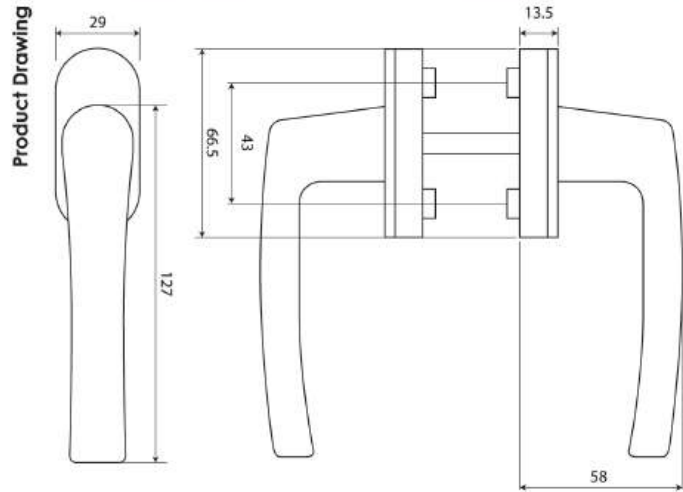

**UDDH-536 DOOR HANDLE**



| Description : One Side Key One Side Handle |        |
|--|--------|
| Code                                       | Finish |
| UDDH-536-B                                 | Black  |
| UDDH-536-W                                 | White  |

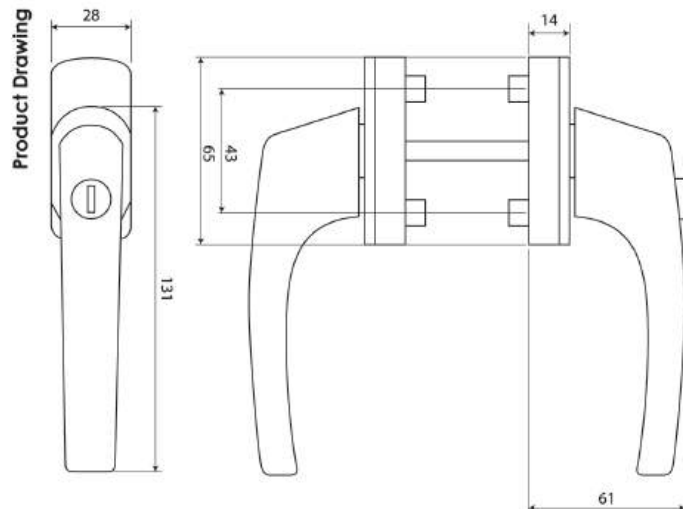



## DOOR HANDLE UDDH-540

### Description : One Side Knob One Side Handle

| Code       | Finish |
|------------|--------|
| UDDH-540-B | Black  |
| UDDH-540-W | White  |

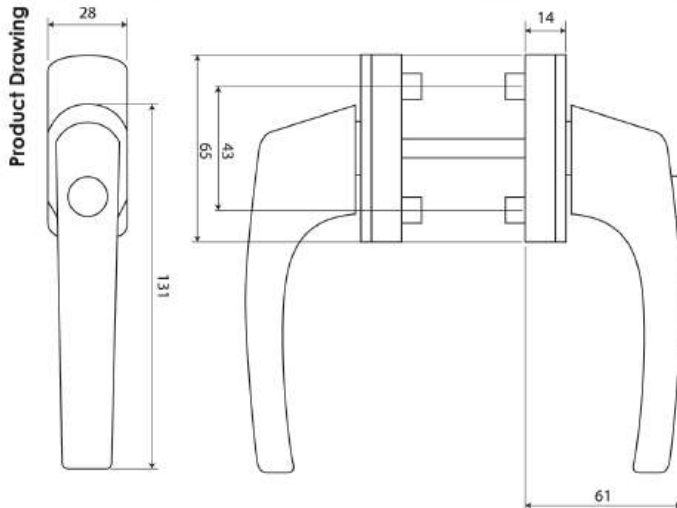

## DOOR HANDLE UDDH-544

### Description : Both Side Key

| Code       | Finish |
|------------|--------|
| UDDH-544-B | Black  |
| UDDH-544-W | White  |

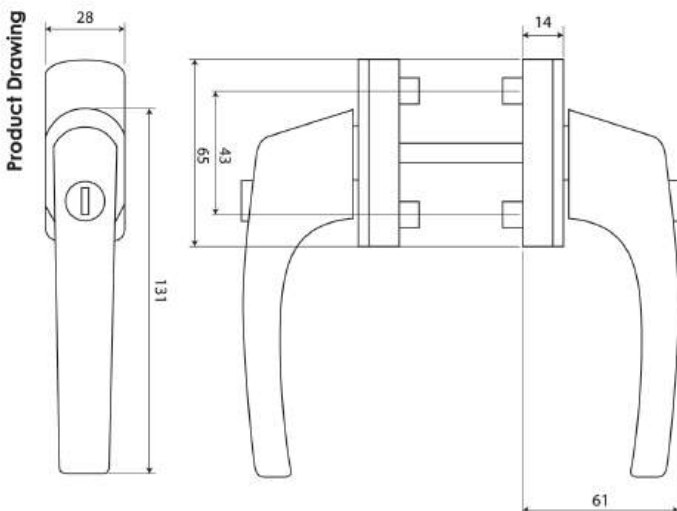

**UMH-548**

**DOOR HANDLE**



| Description : Door Handle |        |
|---------------------------|--------|
| Code                      | Finish |
| UMH-548-B                 | Black  |
| UMH-548-W                 | White  |

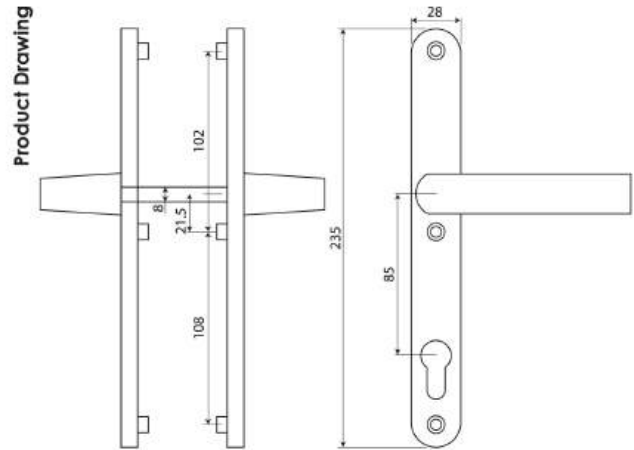

**UMH-552**

**DOOR HANDLE**



| Description : Door Handle |        |
|---------------------------|--------|
| Code                      | Finish |
| UMH-552-B                 | Black  |
| UMH-552-W                 | White  |

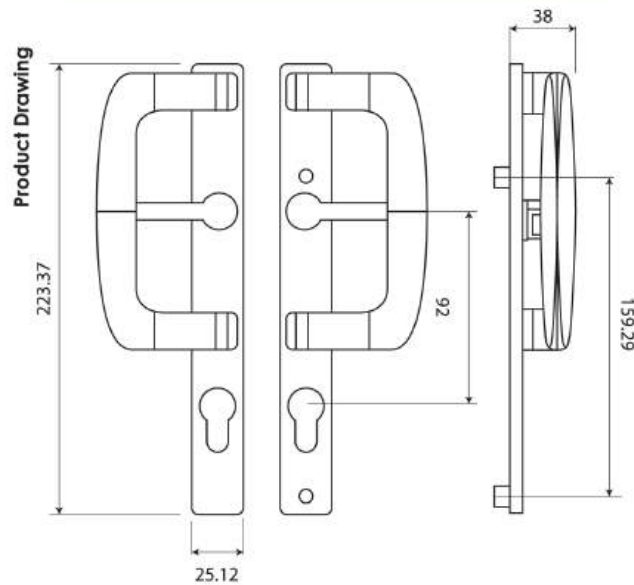

## DOOR ACCESSORIES

ULB

**Description : Lock Body with Plate**

| Code     | Finish | Hole Distance |
|----------|--------|---------------|
| ULB-8520 | SS     | 20mm          |
| ULB-8525 | SS     | 25mm          |
| ULB-8530 | SS     | 30mm          |

Product Drawing

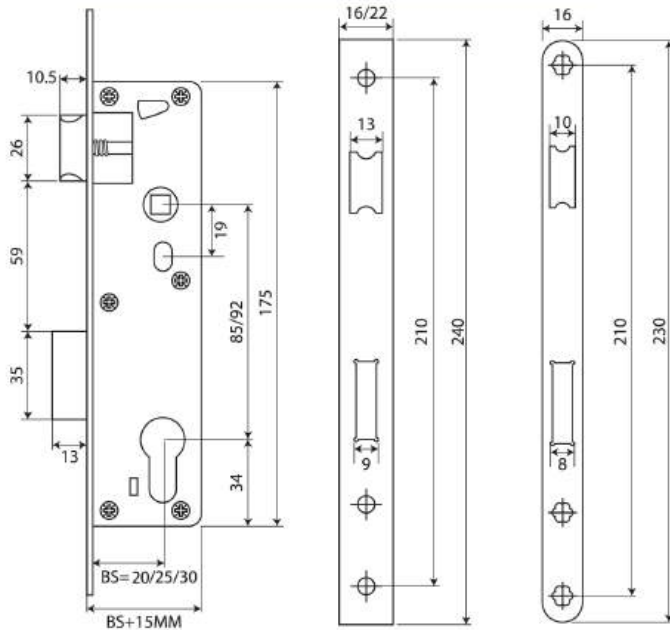

ULB-8525



## DOOR ACCESSORIES

UCY

UCY-KN



**Description : Brass Cylinder**

| Code      | Material | Length |
|-----------|----------|--------|
| UCY-60-KN | Brass    | 60mm   |
| UCY-70-KN | Brass    | 70mm   |
| UCY-90-KN | Brass    | 90mm   |

UCY-CAP-W



**Description : Key Hole**

| Code      | Finish |
|-----------|--------|
| UCY-CAP-B | Black  |
| UCY-CAP-W | White  |

# UTR

# ESPAG ROD

UTR-75

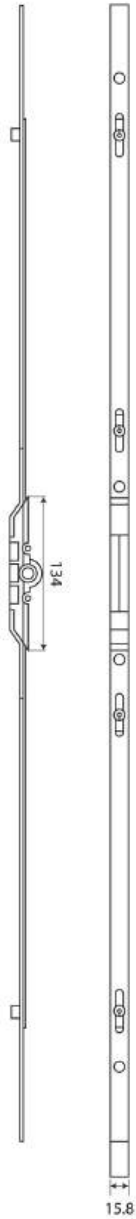

UTR-15

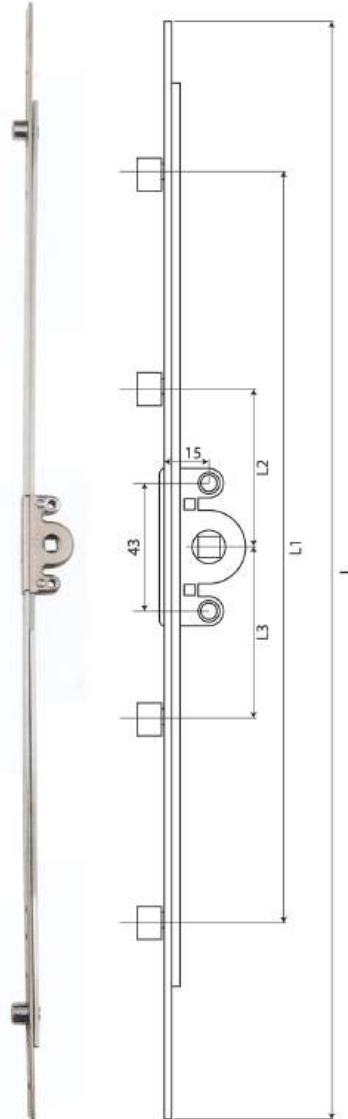

UTR-22

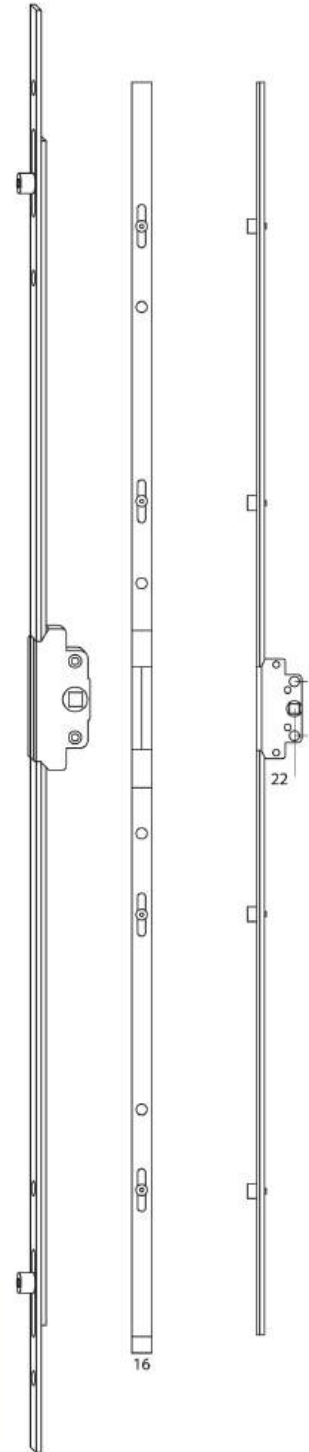

| Code        | Back Set | Length |
|-------------|----------|--------|
| UTR-75-400  | 7.5mm    | 400mm  |
| UTR-75-600  | 7.5mm    | 600mm  |
| UTR-75-800  | 7.5mm    | 800mm  |
| UTR-75-1000 | 7.5mm    | 1000mm |
| UTR-75-1200 | 7.5mm    | 1200mm |
| UTR-75-1400 | 7.5mm    | 1400mm |
| UTR-75-1600 | 7.5mm    | 1600mm |
| UTR-75-1800 | 7.5mm    | 1800mm |

| Code        | Back Set | Length |
|-------------|----------|--------|
| UTR-15-400  | 15mm     | 400mm  |
| UTR-15-600  | 15mm     | 600mm  |
| UTR-15-800  | 15mm     | 800mm  |
| UTR-15-1000 | 15mm     | 1000mm |
| UTR-15-1200 | 15mm     | 1200mm |
| UTR-15-1400 | 15mm     | 1400mm |
| UTR-15-1600 | 15mm     | 1600mm |
| UTR-15-1800 | 15mm     | 1800mm |

| Code        | Back Set | Length |
|-------------|----------|--------|
| UTR-22-400  | 22mm     | 400mm  |
| UTR-22-600  | 22mm     | 600mm  |
| UTR-22-800  | 22mm     | 800mm  |
| UTR-22-1000 | 22mm     | 1000mm |
| UTR-22-1200 | 22mm     | 1200mm |
| UTR-22-1400 | 22mm     | 1400mm |
| UTR-22-1600 | 22mm     | 1600mm |
| UTR-22-1800 | 22mm     | 1800mm |

ESPAG ROD

UTR

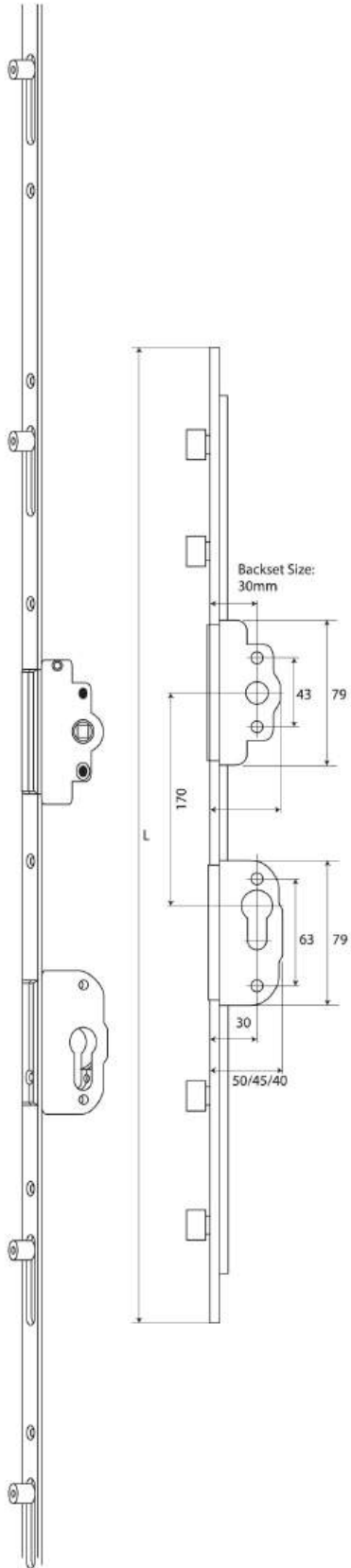

UTR-CW

| Code        | Back Set | Length |
|-------------|----------|--------|
| UTR-CW-1800 | 30mm     | 1800mm |

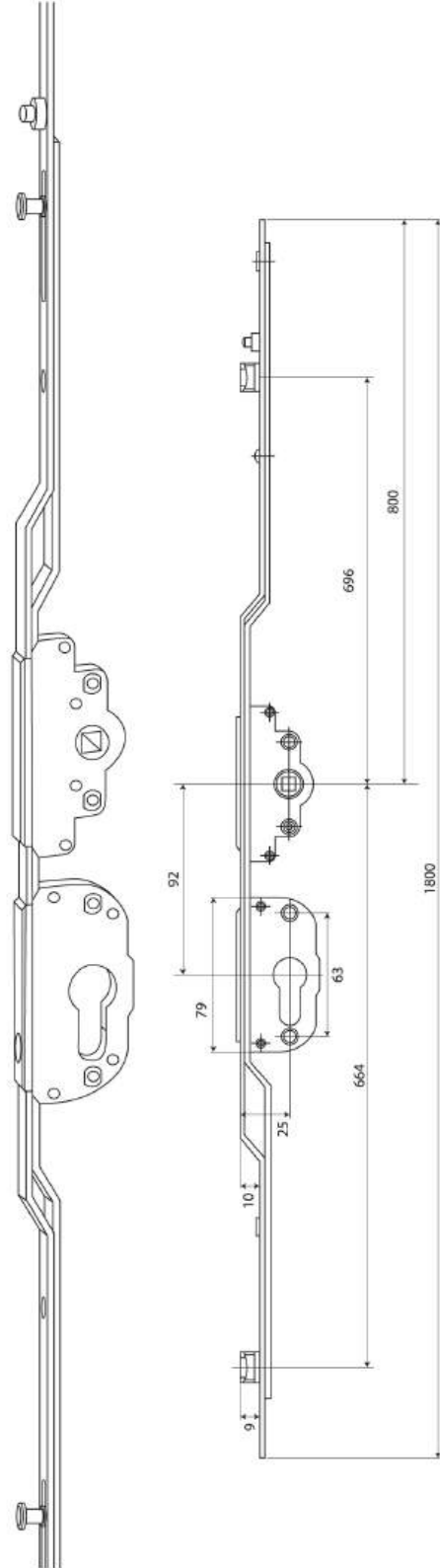

UTR-MH

| Code        | Back Set | Length |
|-------------|----------|--------|
| UTR-MH-1800 | 15mm     | 1800mm |

## UHN-FT-564 FLAT HINGE



UHN-FT-564-W

### Description : Flat Hinge

| Code         | Finish | Type | Weight Capacity |
|--------------|--------|------|-----------------|
| UHN-FT-564-W | White  | 2D   | 40 kg.          |

Product Drawing

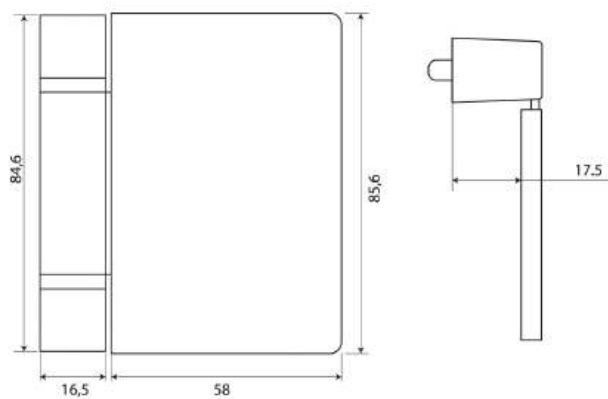

## UHN-FT-568 FLAT HINGE



UHN-FT-568-W

### Description : Flat Hinge

| Code         | Finish | Type | Weight Capacity |
|--------------|--------|------|-----------------|
| UHN-FT-568-W | White  | 2D   | 40 kg.          |

Product Drawing

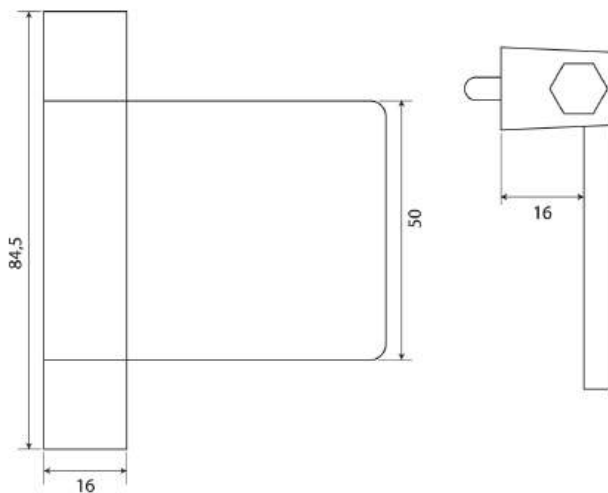

## 3D HINGE

UHN-3D-572

## Description : 3D Hinge

| Code         | Finish | Type | Weight Capacity |
|--------------|--------|------|-----------------|
| UHN-3D-572-W | White  | 3D   | 100 kg.         |

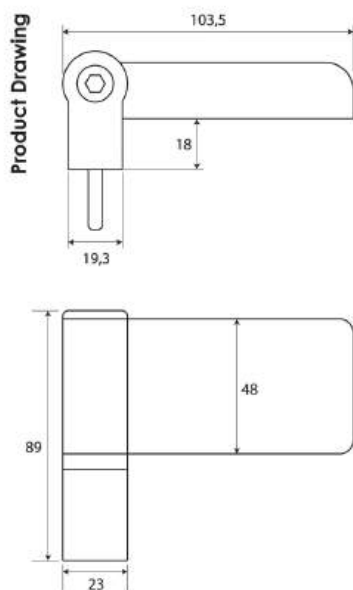

UHN-3D-572-W

## CONCEAL HINGE

UHN-576

## Description : Conceal Hinge

| Code      | Finish | Type    |
|-----------|--------|---------|
| UHN-576-W | White  | Conceal |

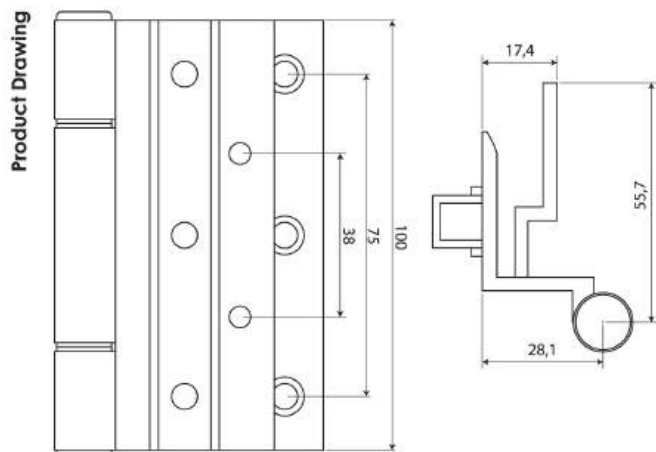

UHN-576-W

**UHN-580 CONCEAL HINGE**



UHN-580-W

| Description : Conceal Hinge |        |         |
|-----------------------------|--------|---------|
| Code                        | Finish | Type    |
| UHN-580-W                   | White  | Conceal |

Product Drawing

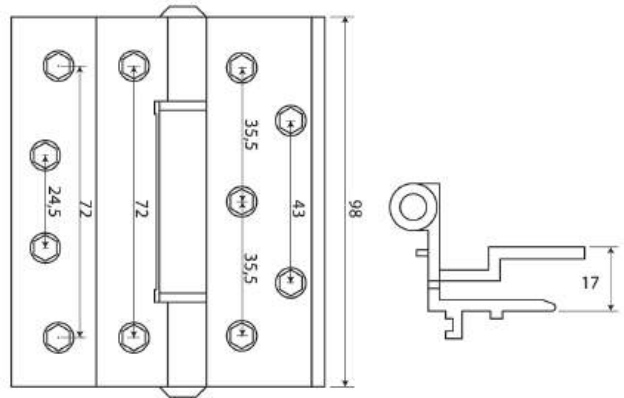

**UHN-584 CONCEAL HINGE**



UHN-584-W

| Description : Conceal Hinge |        |         |
|-----------------------------|--------|---------|
| Code                        | Finish | Type    |
| UHN-584-W                   | White  | Conceal |

Product Drawing

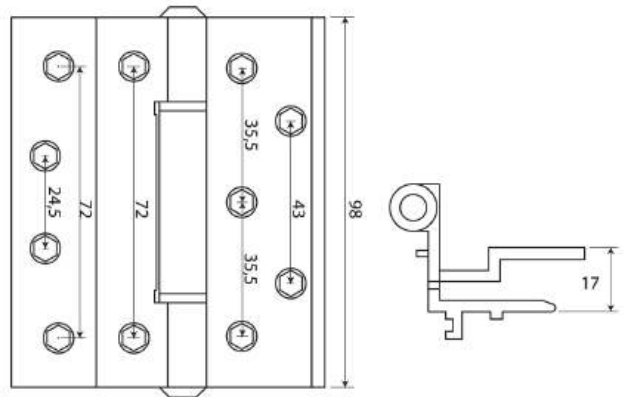



## CRESCENT HANDLE

UCR-556

## Description : Crescent Handle

| Code       | Finish | L & R |
|------------|--------|-------|
| UCR-556-RW | White  | Right |
| UCR-556-LW | White  | Left  |

Product Drawing

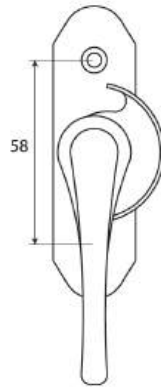
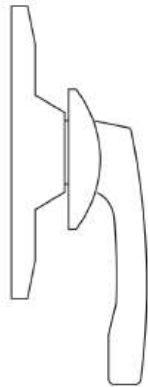
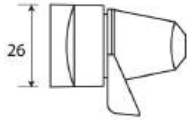

UCR-556-RW



## T-LOCK HANDLE

UTL-560

## Description : T-Lock Handle

| Code      | Finish |
|-----------|--------|
| UTL-560-W | White  |

Product Drawing

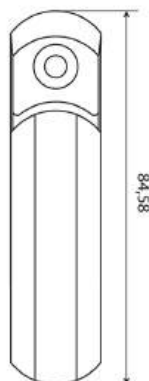
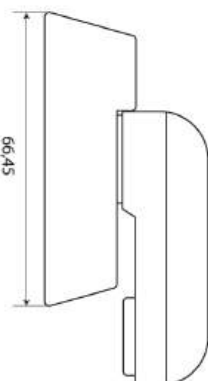
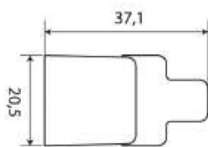

UTL-560-W



UWR

## WINDOW ROLLER



Product Drawing

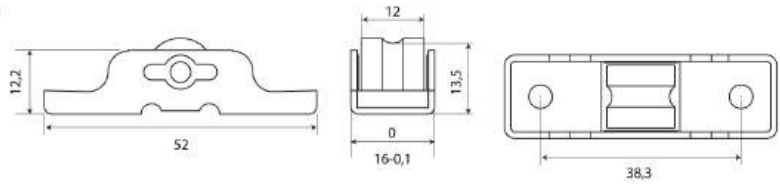

## Description : Window Roller

| Code       | Finish | Material |
|------------|--------|----------|
| UWR-605-MS | SS     | MS       |
| UWR-615-SS | SS     | SS       |

UWR

## WINDOW ROLLER



Product Drawing

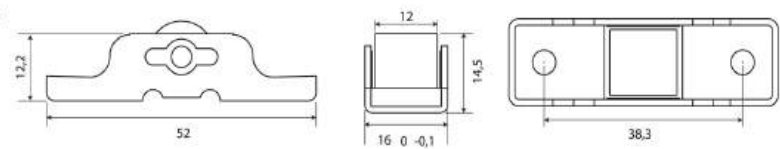

## Description : Window Roller

| Code       | Finish | Material |
|------------|--------|----------|
| UWR-610-MS | SS     | MS       |
| UWR-620-SS | SS     | SS       |

UWR

## WINDOW ROLLER



Product Drawing

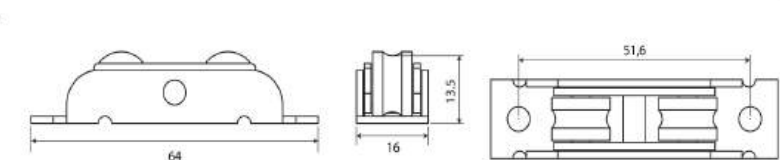

## Description : Window Roller (Adjustable)

| Code       | Finish | Material |
|------------|--------|----------|
| UWR-625-MS | SS     | MS       |
| UWR-630-SS | SS     | SS       |

UWR

## WINDOW ROLLER



Product Drawing

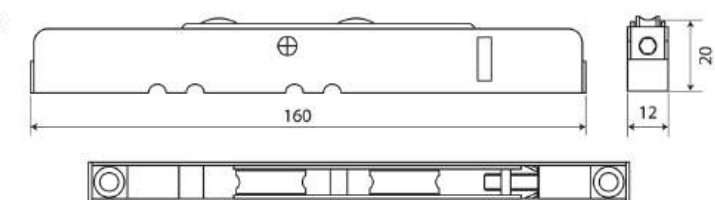

## Description : Window Roller (Adjustable)

| Code       | Finish | Material |
|------------|--------|----------|
| UWR-635-MS | SS     | MS       |
| UWR-640-SS | SS     | SS       |

## WINDOW ROLLER

UWR

Product Drawing

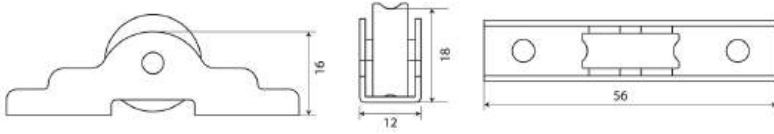

**Description : Window Roller**

| Code       | Finish | Material |
|------------|--------|----------|
| UWR-645-MS | SS     | MS       |



## WINDOW ROLLER

UWR

**Description : Window Roller**

| Code       | Finish | Width |
|------------|--------|-------|
| UWR-650-MQ | White  | 10mm  |



## WINDOW ROLLER

UWR

Product Drawing

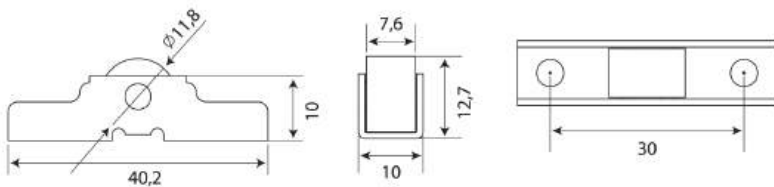

**Description : Window Roller**

| Code       | Material | Width |
|------------|----------|-------|
| UWR-655-MQ | MS       | 10mm  |



## WINDOW ROLLER

UWR

**Description : Window Roller**

| Code       | Finish | Width |
|------------|--------|-------|
| UWR-660-MQ | White  | 7.5mm |



  
Excellenza®

etto®

**ATUL BRASS WORKS**

Importers & Exporter of Builders Hardware

**Registered Office :**

303/A, Byculla Service Industries,  
Dadoji Konddev Cross Marg, Byculla(E),  
Mumbai 400027. INDIA

**Tel** : +91 22 49713119

**Email** : atulbrass@hotmail.com

**Web** : [www.excellenza.co.in](http://www.excellenza.co.in)